



EnergyPlus Testing with ASHRAE 1052-RP Toolkit – Building Fabric Analytical Tests

EnergyPlus Version 4.0.0.024

October 2009

Prepared for:

U.S. Department of Energy
Energy Efficiency and Renewable Energy
Office of Building Technologies
Washington, D.C.

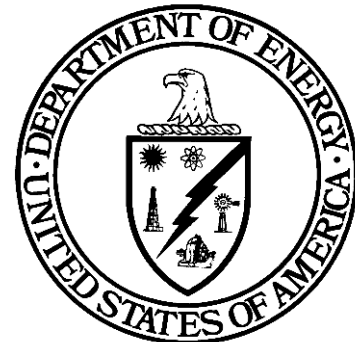

Prepared by:

Robert H. Henninger and Michael J. Witte

GARDAnalytics

Energy, Economic and Environmental Research:

115 S. Wilke Road, Suite 115

Arlington Heights, IL 60005

USA

www.gard.com

This report is based upon work supported by the Ernest Orlando Lawrence Berkeley National Laboratory and the Department of Energy National Energy Technology Laboratory under award number DE-FC26-06NT42768 by subcontract through the University of Central Florida/Florida Solar Energy Center.

This report was prepared as an account of work sponsored by an agency of the United States Government. Neither the United States Government nor any agency thereof, nor any of their employees, makes any warranty, express or implied, or assumes any legal liability or responsibility for the accuracy, completeness, or usefulness of any information, apparatus, product, or process disclosed, or represents that its use would not infringe privately owned rights. Reference herein to any specific commercial product, process, or services by trade name, trademark, manufacturer, or otherwise does not necessarily constitute or imply its endorsement, recommendation, or favoring by the United States Government or any agency thereof. The views and opinions of authors expressed herein do not necessarily state or reflect those of the United States Government or any agency thereof.

Table of Contents

Section	Page
1 TEST OBJECTIVES AND OVERVIEW	1
1.1 Test Type: Analytical.....	1
1.2 Test Suite: ASHRAE 1052-RP Toolkit.....	1
2 RESULTS AND DISCUSSION	5
2.1 Test SSConv – Steady State Convection.....	5
2.2 Test SSCond – Steady State Conduction.....	6
2.3 Test TC1 –Transient Conduction, Adiabatic Wall.....	7
2.4 Test TC2 – Transient Conduction, Step Response.....	8
2.4.1 Step-Up in External Temperature.....	8
2.4.2 Step-Down in External Temperature.....	9
2.5 Test TC3 – Transient Conduction, Sinusoidal Driving Temperature and Multi-Layer Wall.....	10
2.6 Test ExtSolRad – Exterior Solar Radiation, Opaque Surfaces.....	11
2.6.1 South Facing Surface.....	11
2.6.2 East Facing Surface.....	13
2.7 Test SolRadGlazing – Solar Radiation, Glazed Surfaces.....	15
2.7.1 South Facing Surface.....	16
2.7.2 East Facing Surface.....	17
2.8 Test SolRadShade – Solar Radiation, Window Shading.....	19
2.8.1 South Facing Surface.....	20
2.8.2 West Facing Surface.....	21
2.9 Test WinReveal – Window Reveal.....	24
2.10 Test IntSolarDist – Internal Solar Distribution.....	26
2.11 Test Infiltration-1, Sensible Infiltration Load, Fixed Infiltration Rate.....	29
2.12 Test Infiltration-2, Stack Effect.....	29
2.13 Test ExtLWRad – External Long Wave Radiation.....	31
2.14 Test IntLWRad – Interior Long Wave Radiation.....	32
2.14.1 Test 1 –Ext. Surf. Emis. = 0.9, Oppos. Surf. Emis. = 0.1, Other Surf. Emis. = 0.3.....	32
2.14.2 Test 2 –Ext. Surf. Emis. = 0.9, All Other Surf. Emis. = 0.1.....	34
2.14.3 Test 3 –All Surf. Emis. = 0.9.....	35
2.15 Test IntHeatGain – Internal Heat Gains, Convective and Radiative.....	37
2.16 Test GrdCoup – Ground Coupling, Slab-on-Grade Floor.....	39
3 ENERGYPLUS PROBLEMS UNCOVERED WHILE USING ASHRAE 1052-RP TOOLKIT	41
3.1 Inverted Coordinates for Shade Fins.....	41

Table of Contents

Section		Page
3.2	Sunlit Areas of Surfaces	44
3.3	Solar Time Shift	45
3.4	Underestimating Peak Cooling Loads with Windows	47
3.5	Summary of Pertinent Changes that Occurred Between Versions of EnergyPlus.....	47
4	CONCLUSIONS.....	51
5	REFERENCES	53

1 TEST OBJECTIVES AND OVERVIEW

1.1 Test Type: Analytical

The ASHRAE 1052-RP Toolkit contains a set of simple analytical tests to test the accuracy of building fabric calculations in building energy analysis programs. Analytical tests compare a program's results to mathematical solutions for simple cases. This is an excellent method to use for assessing the accuracy of results since there is only one solution for the case analyzed given the boundary conditions. Analytical testing accomplishes results on two different levels, both validation and debugging. Validation is accomplished when the results of the test program compare favorably with the analytical results. Debugging is accomplished when the results for certain cases do not compare favorably with the analytical results and then through systematic checking it is determined that the source of the difference is due to an input error, a modeling inconsistency or flaw in the program logic.

1.2 Test Suite: ASHRAE 1052-RP Toolkit

The tests described in ASHRAE's report titled *Development of an Analytical Verification Test Suite for Whole Building Energy Simulation Programs – Building Fabric*, dated April 2001, (Spitler 2001) were performed.

As stated in the report's "Introduction to the Test Documentation":

"A series of tests have been developed that are designed to help verify the ability of whole building energy simulation programs to model various aspects of heat transfer through the building fabric. These tests are each based on analytical solutions. These tests are for testing models relating to heat transfer through the building fabric, and not primary or secondary HVAC systems."

"The objective in each test is usually to test the ability of a building energy analysis program to model a particular heat transfer phenomena. This is done by comparing the test program output with the analytical solution for a special test zone. The data to be compared may be a single load or flux, or hourly loads over one or more days of output. In order to make each test specific and help diagnose problems it is necessary to minimize the number of heat transfer paths (and hence number of models involved). This requires the use of test zones that are rather different in their construction and specification than normal building zones."

The ASHRAE 1052-RP test suite consists of 16 different tests which, as explained in the ASHRAE report, can be organized into groups relating to particular heat transfer phenomena as shown in Table 1 below.

Table 1 ASHRAE 1052-RP Case Descriptions

Test Group	Test Name	Code
Group 1 – Convection & Conduction	Steady-State Convection	SSConv
	Steady State Conduction	SSCond
	Transient Conduction – Adiabatic Wall	TC1
	Transient Conduction – Step Response	TC2
	Transient Conduction – Sinusoidal Driving Temperature and Multi-Layer Wall	TC3
Group 2 – Solar Gains & Shading	Exterior Solar Radiation – Opaque Surfaces	ExtSolRad
	Solar Radiation – Glazed Surfaces	SolRadGlazing
	Solar Radiation – Window Shading	SolRadShade
	Solar Radiation – Window Reveal Shading	WinReveal
	Solar Radiation – Internal Solar Distribution	IntSolarDist
Group 3 - Infiltration	Infiltration – Fixed Infiltration Rate	Infiltration-1
	Infiltration – Stack Effect	Infiltration-2
Group 4 – Long Wave Radiation	Interior Long Wave Radiation	IntLWRad
	External Long Wave Radiation	ExtLWRad
Group 5 – Miscellaneous	Internal Heat Gains – Convective and Radiative	IntHeatGain
	Ground Coupling – Slab-on-Ground Floor	GrdCoup

All tests indicated in Table 1 were run with EnergyPlus Version 4.0.0.024.

The test suite uses a cube shaped zone of 3m x 3m x 3m internal dimensions. Depending on which test is being performed, the surfaces of the zone are either exposed to ambient or are adiabatic. For two of the tests, IntLWRad and IntSolarDist, the aspect ratio of the zone is varied. The toolkit user is prompted for inside and outside temperatures, inside and outside convection coefficients, exterior envelope properties (for opaque surfaces and windows), shading parameters, location (4 cities available), date (2 dates available) and internal load level.

Output from each test takes the form of a text file listing the analytical results which usually include the inside and outside surface temperatures and the steady state zone load. A weather file in the user chosen format is also created for use with the test program.

The use of the ASHRAE 1052-RP test suite with EnergyPlus required the following steps for each case:

1. Prepare the EnergyPlus input (IDF) file which will simulate the Zone Description and Test Parameters as specified for a particular test
2. Run the 1052-RP Toolkit software for a particular test to create a weather file in TMY2 format for the location chosen
3. Convert the TMY2 weather file for use with EnergyPlus using the EnergyPlus weather conversion software
4. Run EnergyPlus for the required time-step and simulation period to create a CSV file containing surface temperature data, surface fluxes, zone load and surface convection coefficient data for each time step. Each run was done with the INSIDE and OUTSIDE CONVECTION ALGORITHM objects set to SIMPLE in order to keep the test surface inside and outside convection coefficients constant throughout the test. Depending whether the test surface was a wall, ceiling or floor, EnergyPlus assigns a different value for the inside coefficient due to difference in direction of heat flow. The inside and outside convection coefficients from EnergyPlus for the test surface were then used with the 1052-RP Toolkit in the following step.
5. Rerun the 1052-RP Toolkit using the test surface inside and outside convection coefficients used by EnergyPlus. Prior to EnergyPlus version 1.1.0, for cases where the EnergyPlus internal surface convection coefficients varied between surfaces, e.g., wall versus floor versus ceiling, the area weighted average of the interior convection coefficients was used with the 1052-RP toolkit. For EnergyPlus version 1.1.0 and later, the interior surface convection coefficients could be set to the same value for all surfaces by using the new ConvectionCoefficients input object. The 1052-RP Toolkit allows the user to let the surface convection coefficients to vary as a function of the temperature difference between the surface and the air by setting values for the coefficients A, C and n in the equation

$$h = A + C(|T_s - T_\infty|)^n$$

For all of the 1052-RP Toolkit tests performed as part of this exercise, C=0.0, n=1 and A was set to the constant coefficient value that was taken from the EnergyPlus simulations. A picture of the 1052-RP Toolkit input screen for the ExtSolRad test with the surface inside convection coefficient = 3.076 and the surface outside convection coefficient = 10.22 is shown on the next page.

6. Compare results

Where a location and test date were required, test cases were run for Atlanta, August 21.

ASHRAE Analytical Test Toolkit (1052-RP)

File Options Help

IntSolarDist | ExtLWRad | IntLWRad | IntHeatGain | Infiltration 1 | Infiltration 2 | GrdCoup | WinReveal
 SSConv | SSCond | TC 1 | TC 2 | TC 3 | **ExtSolRad** | SolRadGlazing | SolRadShade

Test Temperatures

Inside temperature (°C)
 Outside temperature (°C)

Test Location Date

Location
 Date

Convection Coefficients

	Coefficient 'A'	Coefficient 'C'	Coefficient 'h'	
Inside correlation	<input type="text" value="3.076"/>	<input type="text" value="0"/>	<input type="text" value="1"/>	(W/m ² .K)
Outside correlation	<input type="text" value="10.22"/>	<input type="text" value="0"/>	<input type="text" value="1"/>	(W/m ² .K)

Fabric Properties

Number of layers	Layer Number	Thickness (m)	Conductivity (W/m.K)
<input type="text" value="3"/>	1	<input type="text" value="0.1"/>	<input type="text" value="1.15"/>
	2	<input type="text" value="0.1"/>	<input type="text" value="1.05"/>
	3	<input type="text" value="0.1"/>	<input type="text" value="1.15"/>

Surface Properties

Surface tilt angle (degree)
 Surface azimuth (degree)
 Solar absorptivity

Status:

2 RESULTS AND DISCUSSION

EnergyPlus results for each of the 16 ASHRAE 1052-RP analytical tests are presented here in this section in either spreadsheet format (for cases where only a single point comparison was required) or chart format (for cases where a time series comparison was required).

2.1 Test SSConv – Steady State Convection

The test zone is made up of five adiabatic surfaces and one external surface which is constructed of a single homogeneous layer with inside temperature held constant at 10°C and outside temperature held constant at 40°C. The single layer had properties as follows:

Thickness	0.1 m
Conductivity	1.0 W/m-K

The effects of solar irradiation, long wave radiation, infiltration, and internal heat gains are eliminated.

Test SSConv: Steady-State Convection (1-layer opaque surface)

Test Parameter	Units	1052RP	EnergyPlus	% Diff
Heat Flux	W/m ²	40.0065	40.0066	0.00%
Zone Load	W	360.06	360.06	0.00%
Inside Surface Temperature	°C	23.01	23.01	0.00%
Outside Surface Temperature	°C	27.01	27.01	0.00%
Inside Convection Coefficient	W/m ² -K	3.076	3.076	
Outside Convection Coefficient	W/m ² -K	3.079	3.079	

Note: Convection coefficients were taken from EnergyPlus and entered into 1052RP Toolkit software
Zone Load = Heat Flux x 9m² surface area

EnergyPlus results for Test SSConv are identical to ASHRAE 1052-RP analytical results.

2.2 Test SSCond – Steady State Conduction

The test zone is made up of one external surface which is a multi-layer homogeneous slab which is massless to avoid transient effects. The slab had properties as follows:

	Thickness (m)	Conductivity (W/m-K)	Density (Kg/m ³)
Layer 1	0.1	0.1	1.0
Layer 2	0.05	0.05	1.0
Layer 3	0.05	0.25	1.0

The inside temperature held constant at 10°C and outside temperature held constant at 40°C. The effects of solar irradiation, long wave radiation, infiltration, and internal heat gains are eliminated.

Test SSCond: Steady-State Conduction (3-layer opaque surface)

Test Parameter	Units	1052RP	EnergyPlus	% Diff
Heat Flux	W/m ²	10.0542	10.0543	0.00%
Zone Load	W	90.49	90.49	0.00%
Inside Surface Temperature	°C	13.27	13.27	0.00%
Outside Surface Temperature	°C	35.39	35.39	0.00%
Inside Convection Coefficient	W/m ² -K	3.076	3.076	
Outside Convection Coefficient	W/m ² -K	2.180	2.180	

Note: Convection coefficients were taken from EnergyPlus and entered into 1052RP Toolkit software
Zone Load = Heat Flux x 9 m² surface area

EnergyPlus results for Test SSCond are identical to ASHRAE 1052-RP analytical results.

2.3 Test TC1 –Transient Conduction, Adiabatic Wall

The test zone is a 3m x 3m x 3m cube with one external surface of homogeneous construction. All other surfaces are adiabatic but remain convectively coupled. The external temperature undergoes a 50°C step change from 20°C to 70°C while the inside temperature is allowed to float in response to the inside surface of the test construction in order to simulate adiabatic conditions at the inside surface of the test wall. The effects of solar irradiation, long wave radiation, infiltration, and internal heat gains are eliminated.

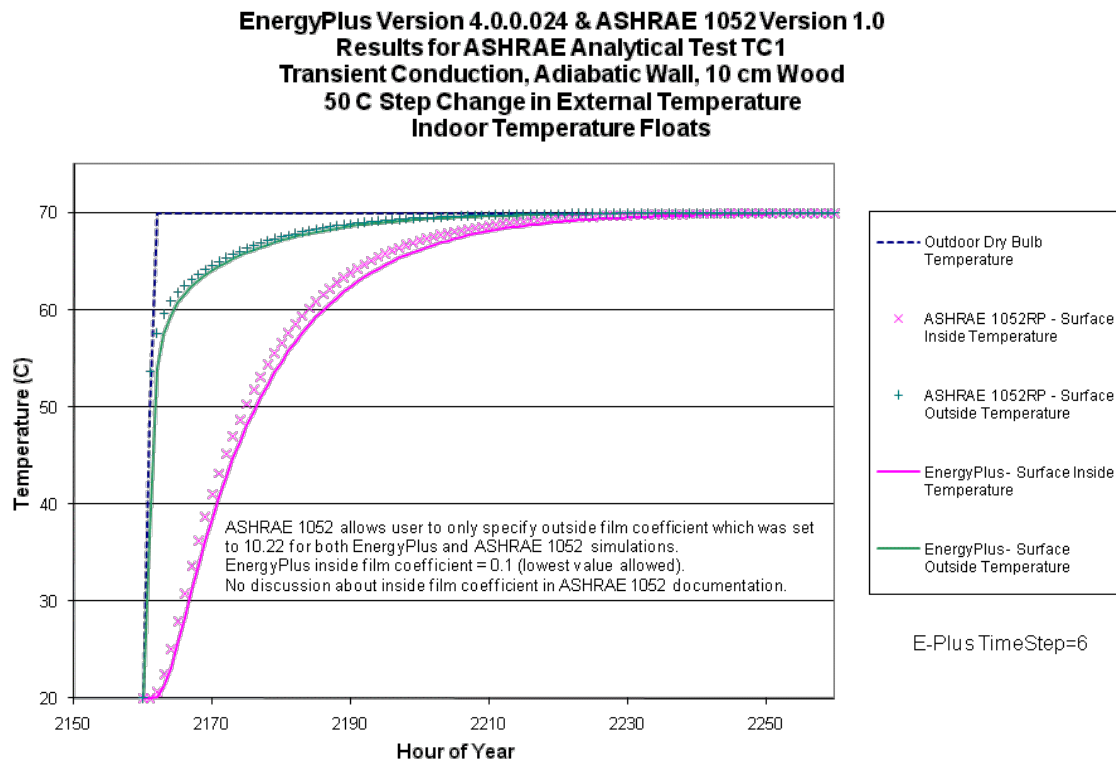

The small disagreement between EnergyPlus and ASHRAE 1052-RP analytical results is thought to be due to not being able to simulate a true adiabatic condition at the inside wall surface in EnergyPlus. The lower limit for the inside convection coefficient in EnergyPlus is 0.1. The ASHRAE 1052-RP toolkit for this test case does not allow the user to set a value for the inside film coefficient since the analytical solution does not require it. The heat balance technique used by EnergyPlus however, does utilize the inside convection coefficient. For the EnergyPlus simulation, the ConvectionCoefficients object was used to fix the outside film coefficient at 10.22 (the default value for the boundary conditions specified) and inside film coefficient at 0.1. For the 1052-RP toolkit, only the outside film coefficient of 10.22 was specified.

2.4 Test TC2 – Transient Conduction, Step Response

The test zone is a 3m x 3m x 3m cube with one external surface of homogeneous construction. All other surfaces are adiabatic but remain convectively coupled. The internal zone air temperature is held constant at 20°C during the test. The external temperature is set at the same temperature, 20°C initially, and then undergoes a 50°C step change up from 20°C to 70°C where it is held constant for a long period of time after which the external temperature undergoes a step change down to -30°C (50°C below the initial setting). The effects of solar irradiation, long wave radiation, infiltration, and internal heat gains are eliminated.

2.4.1 Step-Up in External Temperature

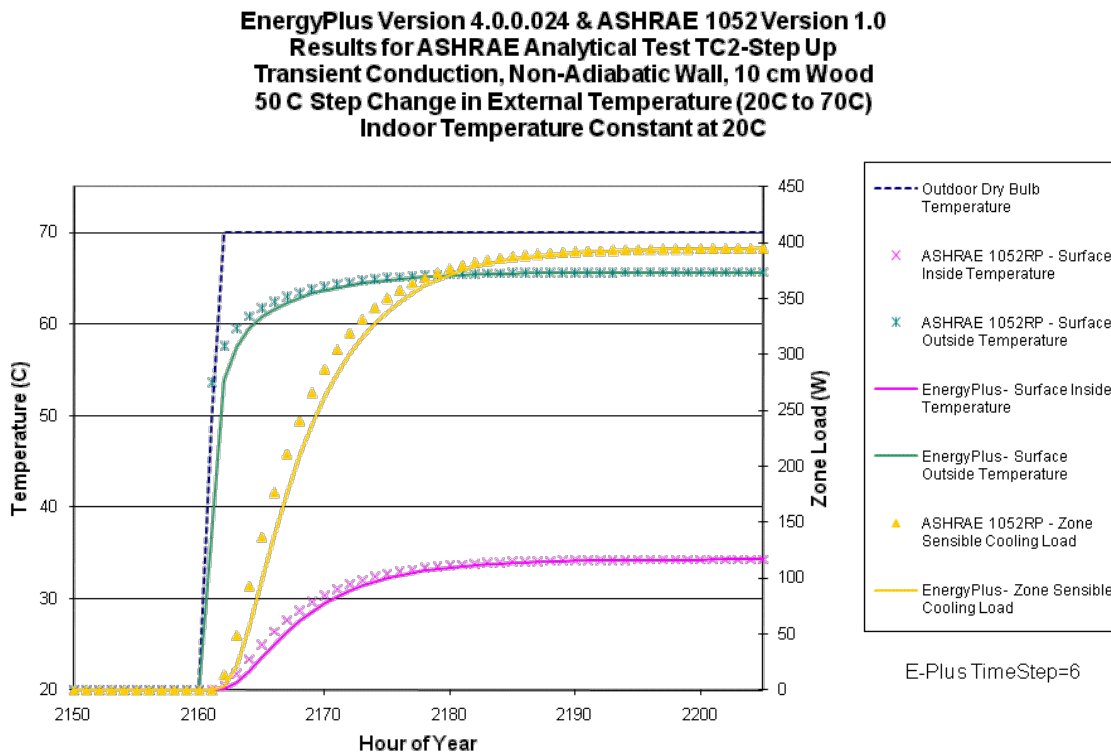

During the transient period before reaching steady state EnergyPlus is predicting lower surface temperatures than ASHRAE 1052-RP. The inside and outside film coefficients for both programs were the same for this test so this is not the source of difference. As seen below, excellent agreement was obtained when comparing the total zone load over the 48-hour period after ramp up in temperature occurs.

Test TC2 – Transient Conduction, Step-Up External Temperature				
Test Parameter	Units	1052RP	EnergyPlus	% Diff
48-Hour Zone Load	W-h	15955	15919	-0.003%

2.4.2 Step-Down in External Temperature

EnergyPlus Version 4.0.0.024 & ASHRAE 1052 Version 1.0
Results for ASHRAE Analytical Test TC2-Step Down
Transient Conduction, Non-Adiabatic Wall, 10 cm Wood
100 C Step Change in External Temperature (70C to -30C)
Indoor Temperature Constant at 20C

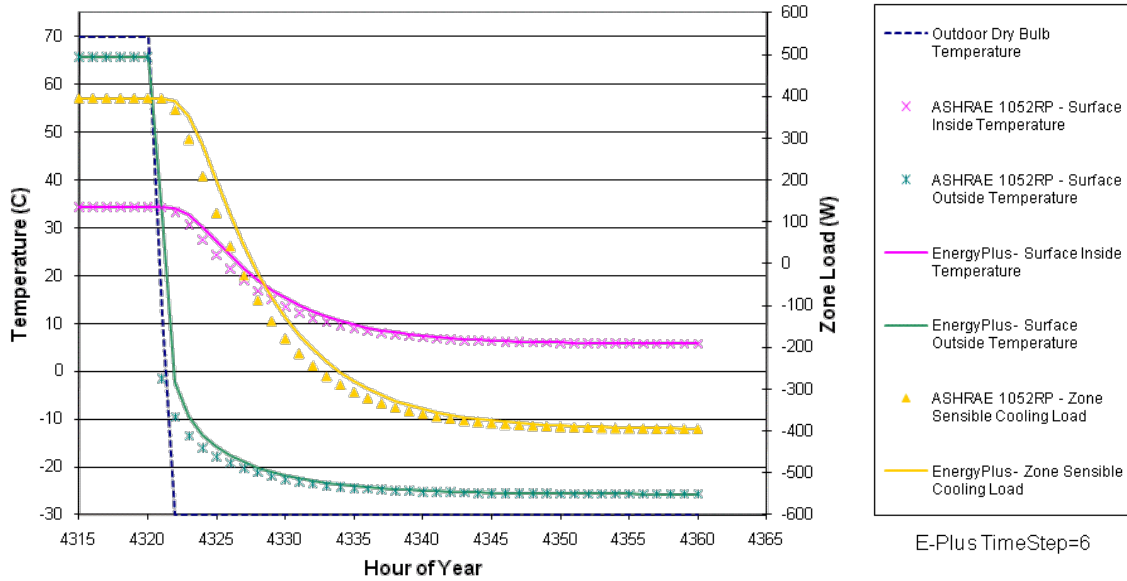

Once again, during the transient period before reaching steady state EnergyPlus is responding slower to the temperature change and predicting slightly higher surface temperatures than ASHRAE 1052-RP but total zone load over the 48-hour period following ramp down in temperature compares well.

Test TC2 – Transient Conduction, Step-Down External Temperature				
Test Parameter	Units	1052RP	EnergyPlus	% Diff
48-Hour Zone Load	W-h	-12917	-12846	0.005%

2.5 Test TC3 – Transient Conduction, Sinusoidal Driving Temperature and Multi-Layer Wall

The test zone is a 3m x 3m x 3m cube with one external surface which is a multi-layer homogeneous slab with convective boundary conditions. The external temperature is a steady-periodic sinusoidal change about a 20°C mean temperature with an amplitude of +15°C and -15°C and a period of fluctuation of 24 hours. All other surfaces are adiabatic but remain convectively coupled. The internal zone air temperature is held constant at the mean external temperature (20°C). The effects of solar irradiation, long wave radiation, infiltration, and internal heat gains are eliminated.

**EnergyPlus Version 4.0.0.024 & ASHRAE 1052 Version 1.0
Results for ASHRAE Analytical Test TC3
Transient Conduction, Non-Adiabatic 3-Layer Wall
Sinusoidal Change in External Temperature
20C mean, 15C amp, 24 hr period
Indoor Temperature Constant at 20C**

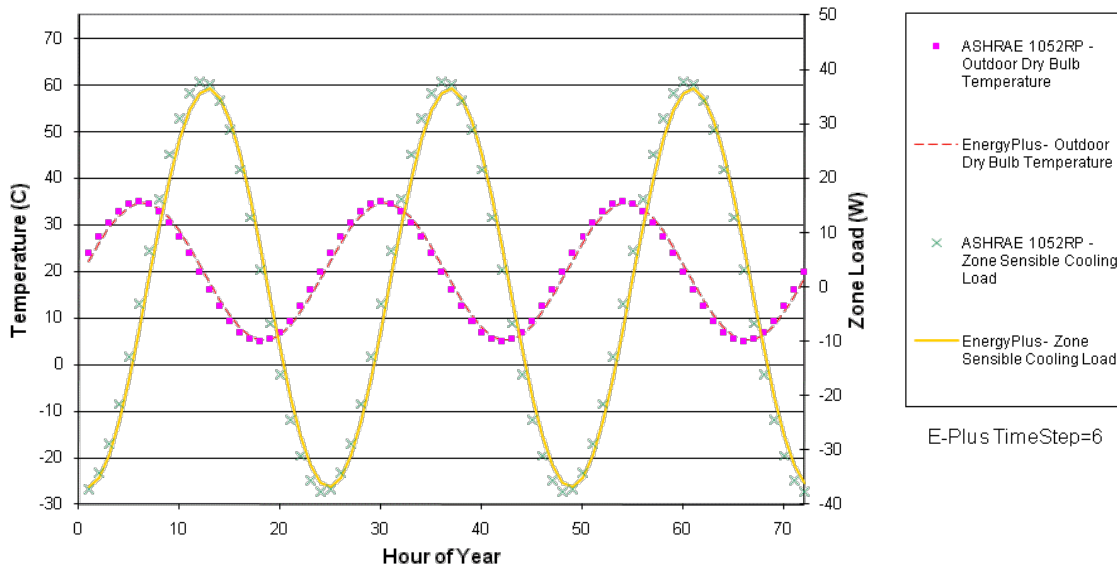

EnergyPlus results track the ASHRAE 1052-RP analytical results well during the warm-up and cool-down periods but does not reach the same extremes that ASHRAE 1052-RP does. There also seems to be a small phase shift between the two programs for both outdoor temperature and zone load. The sum of the absolute value of the zone load over a 24-hour period is within 3%.

Test TC3 – Transient Conduction, Sinusoidal Temperature

Test Parameter	Units	1052RP	EnergyPlus	% Diff
24-Hour Absolute Zone Load	W-h	578	561	-2.9%

2.6 Test ExtSolRad – Exterior Solar Radiation, Opaque Surfaces

The test zone is similar to that described in Test SSCond with a multi-layer external surface. Except for the external surface, all other surfaces are adiabatic and have no thermal mass. The inside and outside temperatures are fixed at 20°C. The effects of long wave radiation, infiltration, and internal heat gains are eliminated. The location was chosen as Atlanta and date set at August 21. Direct normal solar radiation at ground level was taken from ASHRAE 1052-RP weather files provided with the software. The external test surface was chosen as having a 90° tilt (vertical) and two orientations -- 180° azimuth (facing south) and 90° azimuth (facing east).

2.6.1 South Facing Surface

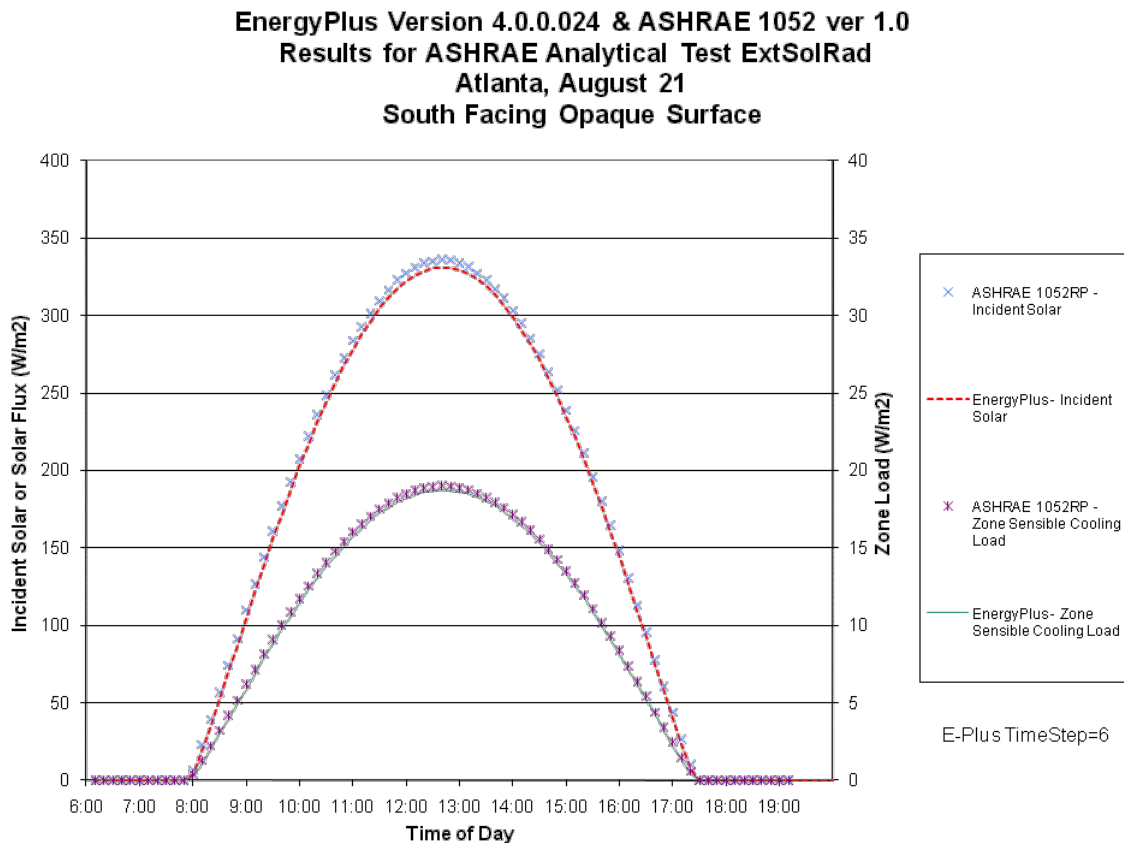

**EnergyPlus Version 4.0.0.024 & ASHRAE 1052 ver 1.0
Results for ASHRAE Analytical Test ExtSolRad
Atlanta, August 21
South Facing Opaque Surface**

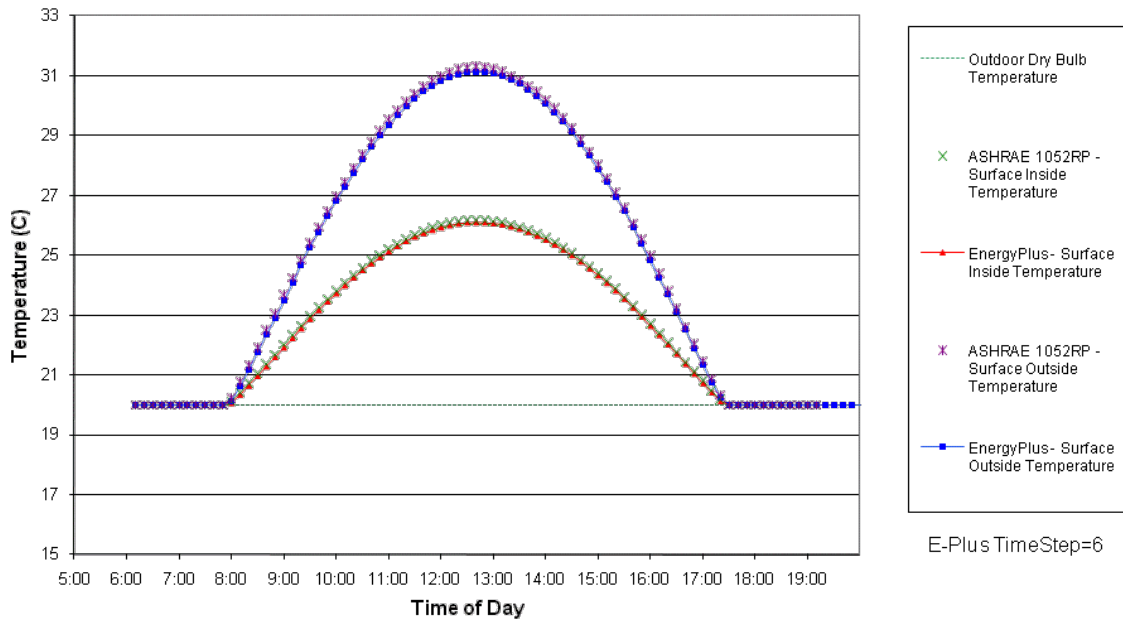

E-Plus TimeStep=6

The results of EnergyPlus compare very well to the analytical results.

Test ExtSolRad – Exterior Solar Radiation, South Facing				
Test Parameter	Units	1052RP	EnergyPlus	% Diff
24-Hour Zone Load	W-h/m ²	680	666	-2.0%
Peak Zone Load	W/m ²	19.02	18.73	-1.5%

The difference in loads may be attributable to a difference methodology for treating polarization of light in the window models. The quote below is from EnergyPlus Change Request (CR) #4793:

" . . . the differences between E+ and 1052 cooling load results are attributed to the different way of calculating beam solar transmittance vs. angle of incidence (E+ polarization averaging is done on the glass layer transmissivity and reflectivity *before* calculating system transmittance and reflectance--which is how WINDOW 5 does it, whereas in 1052 the system transmittance and reflectance are calculated for each polarization and then averaged."

2.6.2 East Facing Surface

EnergyPlus Version 4.0.0.024 & ASHRAE 1052 ver 1.0
 Results for ASHRAE Analytical Test ExtSolRad
 Atlanta, August 21
 East Facing Opaque Surface

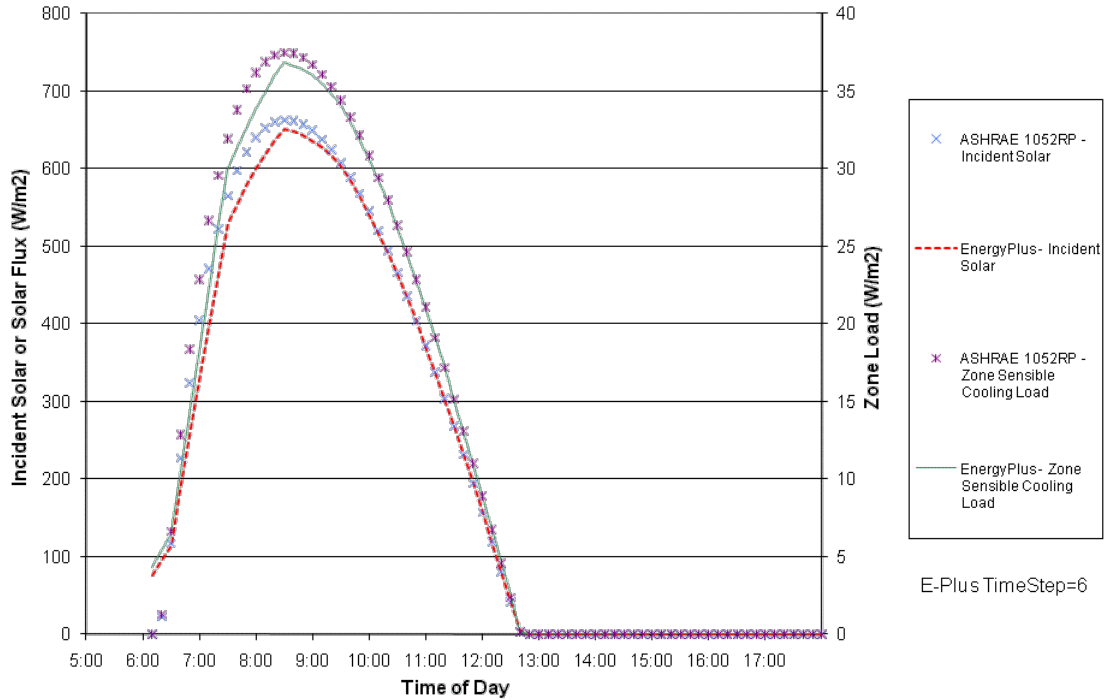

EnergyPlus Version 4.0.0.024 & ASHRAE 1052 ver 1.0
 Results for ASHRAE Analytical Test ExtSolRad
 Atlanta, August 21
 East Facing Opaque Surface

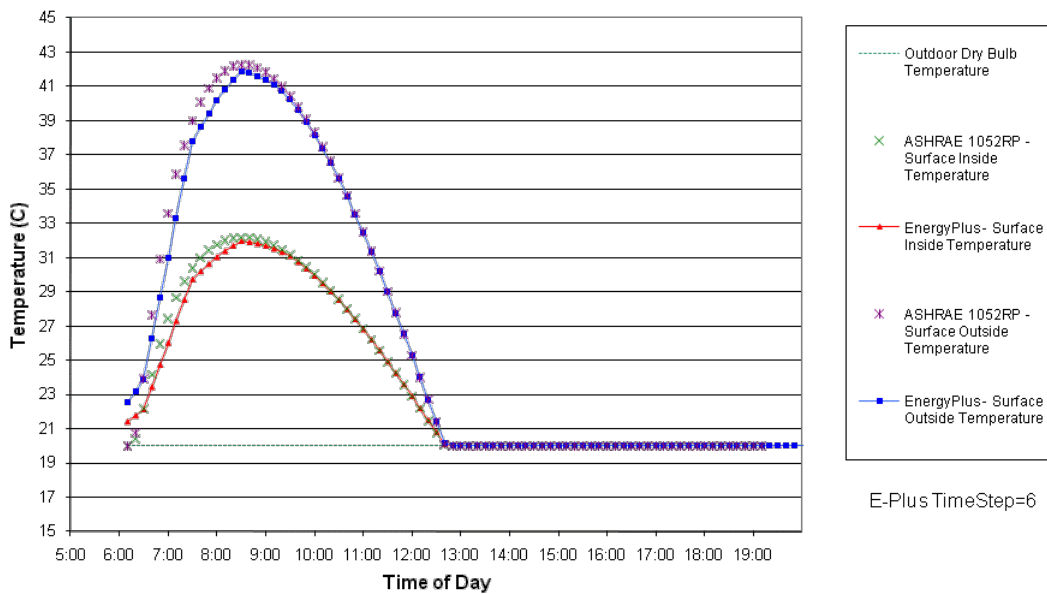

Test ExtSolRad – Exterior Solar Radiation, East Facing

Test Parameter	Units	1052RP	EnergyPlus	% Diff
24-Hour Zone Load	W-h/m ²	931	903	-3.0%
Peak Zone Load	W/m ²	37.48	36.83	-1.7%

The results for the east facing test surface show some differences in the shape of the curves. The curves for the 1052-RP Toolkit have a smooth shape while the EnergyPlus curves are more jagged. It was thought that this difference in shape is due to the interpolation that EnergyPlus must do to get 10 minute increment weather for the simulation. Usually each test contained with the ASHRAE 1052-RP Toolkit produces two out files – one with analytical results on a 10 minute increment basis and a weather file containing hourly weather data in TMY2 format. EnergyPlus then must interpolate the hourly temperature and solar data from the weather file to get weather data for the 10 minute timestep simulation periods. This creates anomalies between the weather data used by the 1052-RP Toolkit and EnergyPlus. To determine what impact this weather processing may have on the results, a special EnergyPlus weather file was created for August 21 for Atlanta with data for each 10 minute increment of every hour. The EnergyPlus simulation was then redone using this special weather file. As shown below, much better agreement resulted with the 1052-RP Toolkit data.

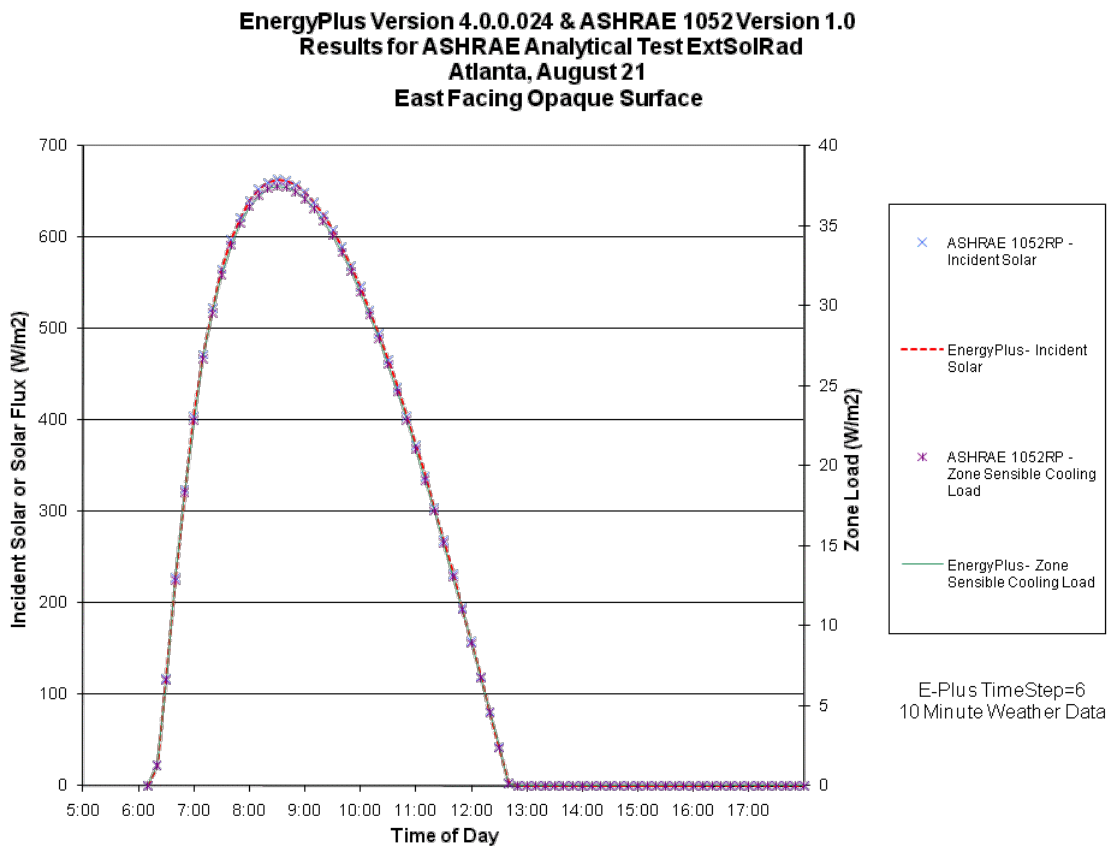

**EnergyPlus Version 4.0.0.024 & ASHRAE 1052 Version 1.0
Results for ASHRAE Analytical Test ExtSolRad
Atlanta, August 21
East Facing Opaque Surface**

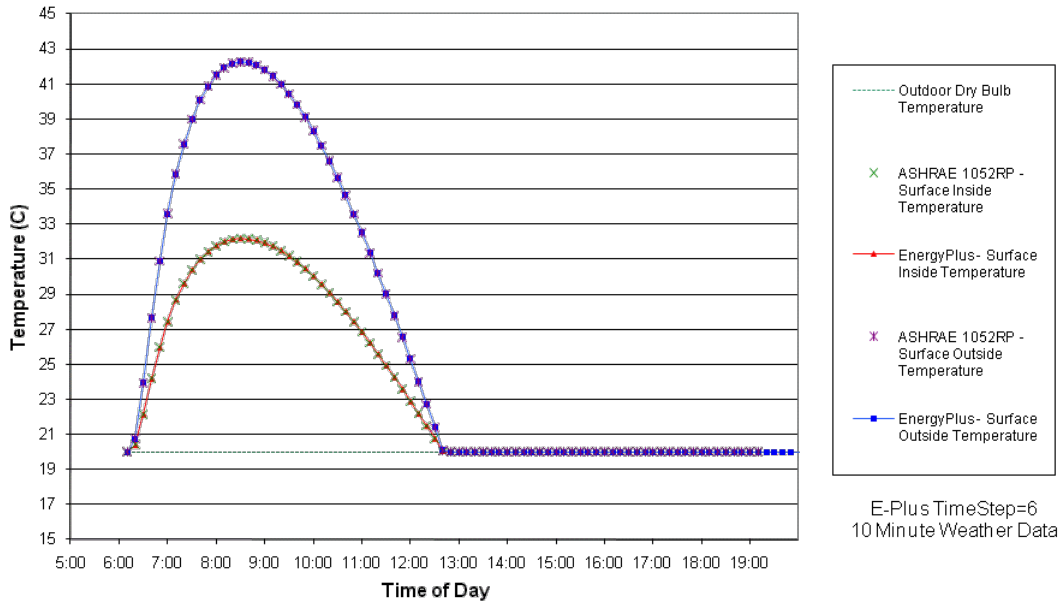

Test ExtSolRad – Exterior Solar Radiation, East Facing, 10 minute weather data

Test Parameter	Units	1052RP	EnergyPlus	% Diff
24-Hour Zone Load	W-h/m ²	931	932	0.11%
Peak Zone Load	W/m ²	37.48	37.47	-0.03%

2.7 Test SolRadGlazing – Solar Radiation, Glazed Surfaces

The test zone is a 3m x 3m x 3m cube with one external surface which is entirely glazed. The window system is a single pane of clear glass with no frame or reveal. It is assumed that the glazed surface has no thermal mass and high conductivity so that it will be of uniform temperature. All other surfaces are black, adiabatic and have no thermal mass. Diffuse radiation is locked out. The inside and outside temperatures are fixed at 20°C. The effects of long wave radiation, infiltration, and internal heat gains are eliminated. The location was chosen as Atlanta and date set at August 21. Direct normal solar radiation at ground level was taken from ASHRAE 1052-RP weather files provided with the software. The external glazed surface was chosen as having a 90° tilt (vertical)) and two orientations -- 180° azimuth (facing south) and 90° azimuth (facing east) .

2.7.1 South Facing Surface

**EnergyPlus Version 4.0.0.024 & ASHRAE 1052 Version 1.0
Results for ASHRAE Analytical Test SolRadGlazing
Atlanta, August 21
South Facing 1/8" Standard Glass**

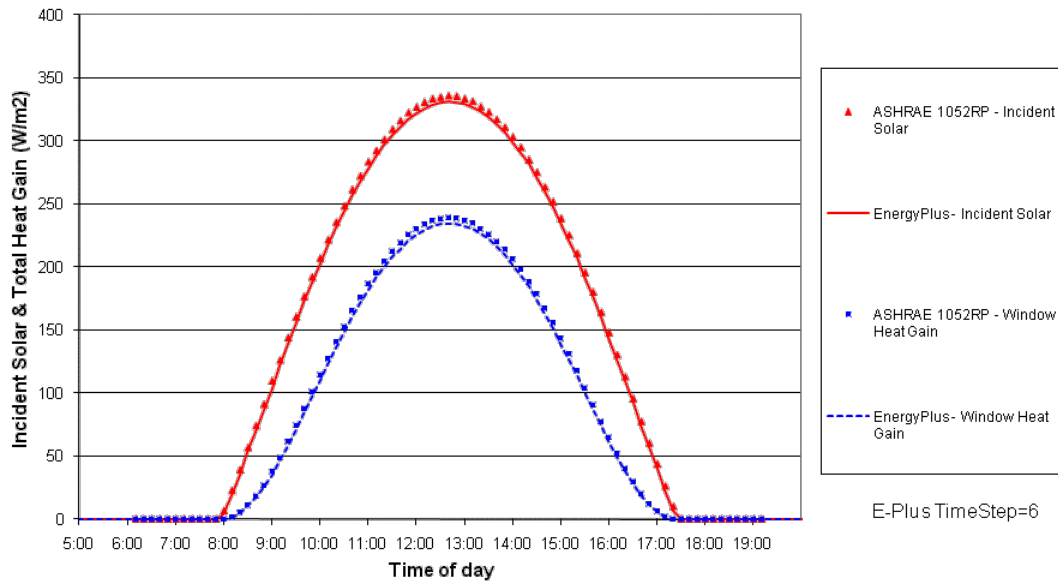

The solar energy incident on the surface for EnergyPlus tracks very well with the analytical results. The curves showing the resultant heat gain in the space have almost identical shapes except that the peak load determined by EnergyPlus is a little smaller than the analytical value.

Test SolRadGlazing – Solar Radiation, South Facing				
Test Parameter	Units	1052RP	EnergyPlus	% Diff
24-Hour Heat Gain	W-h/m ²	7365	7172	-2.6%
Peak Load	W/m ²	239.5	234.5	-2.1%

2.7.2 East Facing Surface

EnergyPlus Version 4.0.0.024 & ASHRAE 1052 Version 1.0
 Results for ASHRAE Analytical Test SolRadGlazing
 Chicago, August 21
 East Facing 1/8" Standard Glass

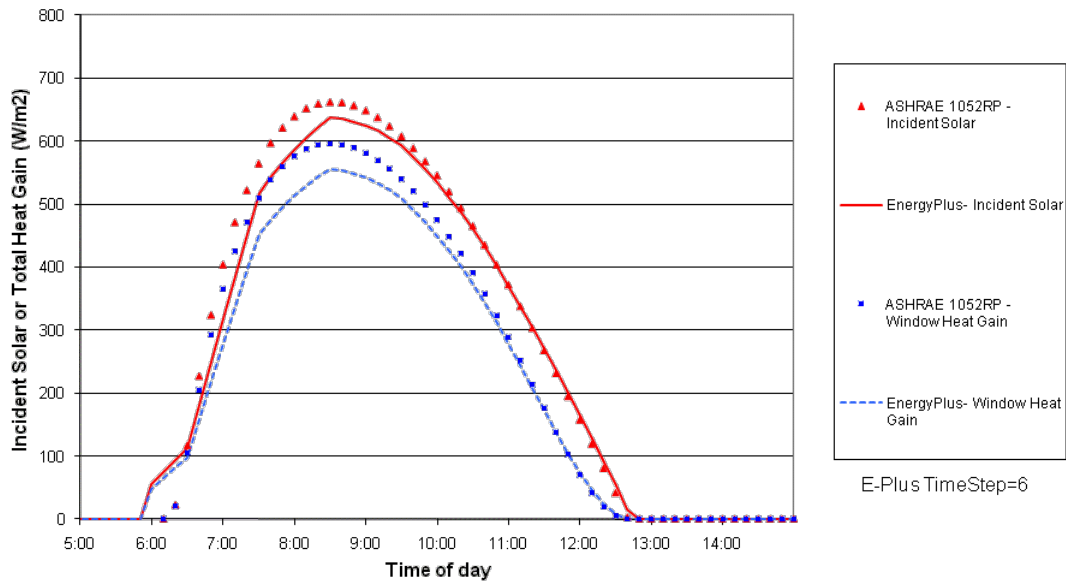

Test SolRadGlazing – Solar Radiation, East Facing

Test Parameter	Units	1052RP	EnergyPlus	% Diff
24-Hour Heat Gain	W-h/m ²	14021	13018	-7.2%
Peak Load	W/m ²	595.96	556.50	-6.6%

As with the ExtSolRad test with an east facing test surface discussed in the previous section, here again there are differences between the EnergyPlus and 1052-RP Toolkit curves. Another simulation was done with EnergyPlus using the same 10 minute weather data file described above and once again the results shown below show much better agreement with the analytical results.

**EnergyPlus Version 4.0.0.024 & ASHRAE 1052 Version 1.0
Results for ASHRAE Analytical Test SolRadGlazing
Chicago, August 21
East Facing 1/8" Standard Glass**

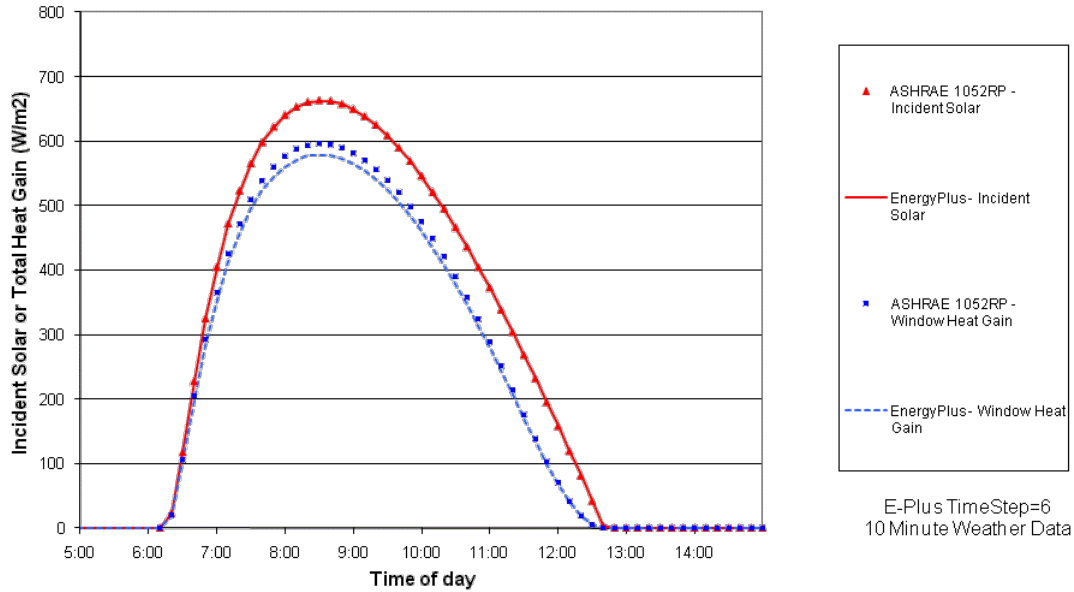

Test SolRadGlazing – Solar Radiation, East Facing, 10 minute weather data

Test Parameter	Units	1052RP	EnergyPlus	% Diff
24-Hour Heat Gain	W-h/m ²	14021	13613	-3.0%
Peak Load	W/m ²	595.96	578.99	-2.9%

2.8 Test SolRadShade – Solar Radiation, Window Shading

The test zone for this test is identical to that described in Section 2.7 except that external shading surfaces are attached to the glazed surface. Three different shade configurations are tested: semi-infinite horizontal fin (overhang), semi-infinite vertical fin, and combination of semi-infinite horizontal and vertical fins (see figure below). The test surface was chosen to have a tilt angle of 90° (vertical) and two orientations – an azimuth of 180° (facing south) and an azimuth of 270° (facing west). The vertical fin was assumed to be attached to the right edge of the glazed surface. The chart below shows results for four situations: no shading, overhang only, vertical fin only, and overhang with fin. Both the “Solar Transmitted” and “Sunlit Area of Surface” as a function of time of day are shown. The total area of the glazed surface is 9m^2 .

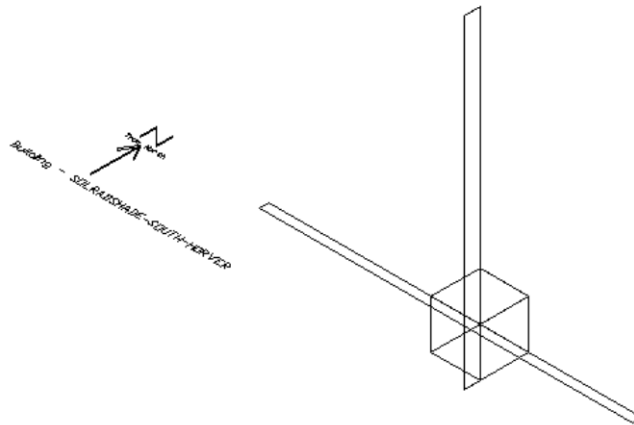

2.8.1 South Facing Surface

**Results for ASHRAE Analytical Test SolRadShade
Zone Solar Load from 9 m2 South Facing Window
with 0.6 m Overhang and/or 1.0 m Right Fin
Atlanta, August 21**

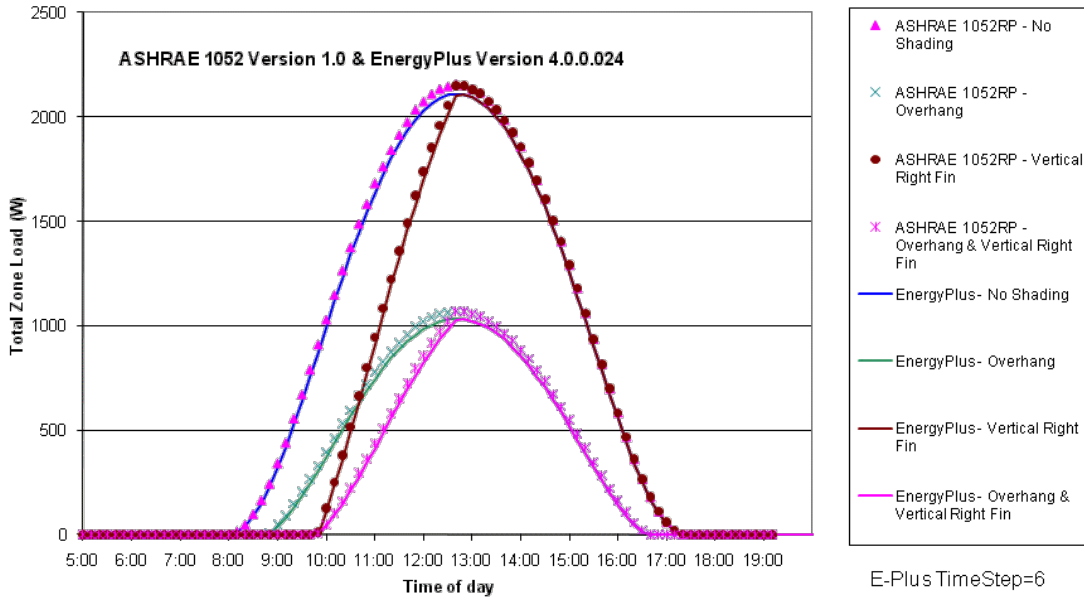

**Results for ASHRAE Analytical Test SolRadShade
Sunlit Area of 9 m2 South Facing Window
with 0.6 m Overhang and/or 1.0 m Right Fin
Atlanta, August 21**

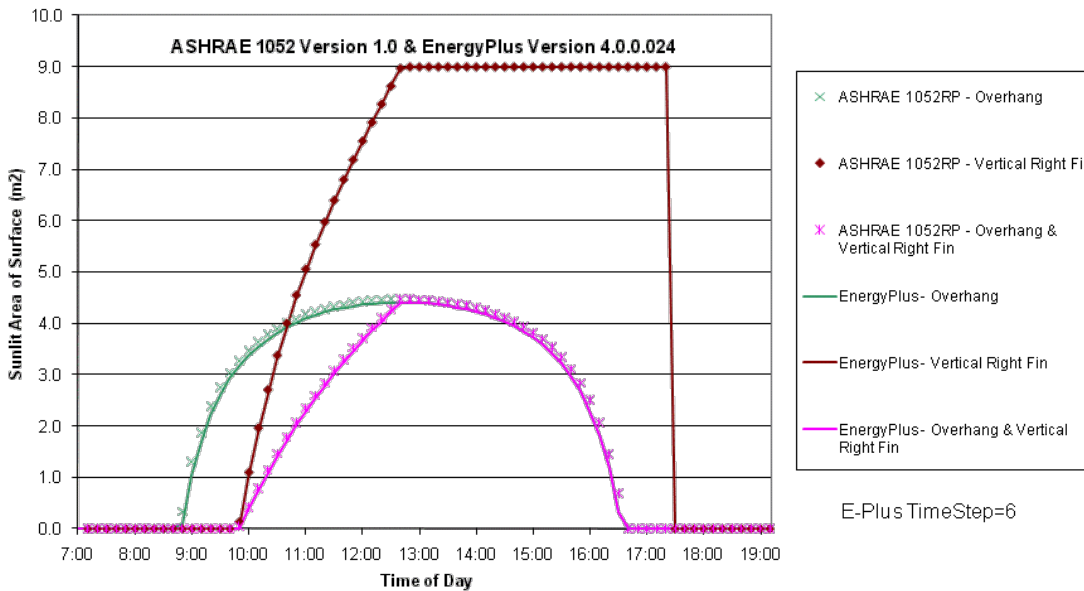

Test SolRadShade – Solar Radiation, Window Shading, South Facing

Test Parameter	Units	1052RP	EnergyPlus	% Diff
-With Overhang				
24-Hour Heat Gain	W-h/m ²	29330	28028	-4.4%
Peak Load	W/m ²	1072	1033	-3.6%
-With Fin				
24-Hour Heat Gain	W-h/m ²	52541	51134	-2.7%
Peak Load	W/m ²	2151	2106	-2.1%
-With Overhang & Fin				
24-Hour Heat Gain	W-h/m ²	23992	22926	-4.4%
Peak Load	W/m ²	1069	1031	-3.6%

EnergyPlus tracks the analytical results very closely and are slightly lower. Peak values for each situation also track very well.

2.8.2 West Facing Surface

**Results for ASHRAE Analytical Test SolRadShade
Sunlit Area of 9 m2 West Facing Window
with 0.6 m Overhang and/or 1.0 m Right Fin
Atlanta, August 21**

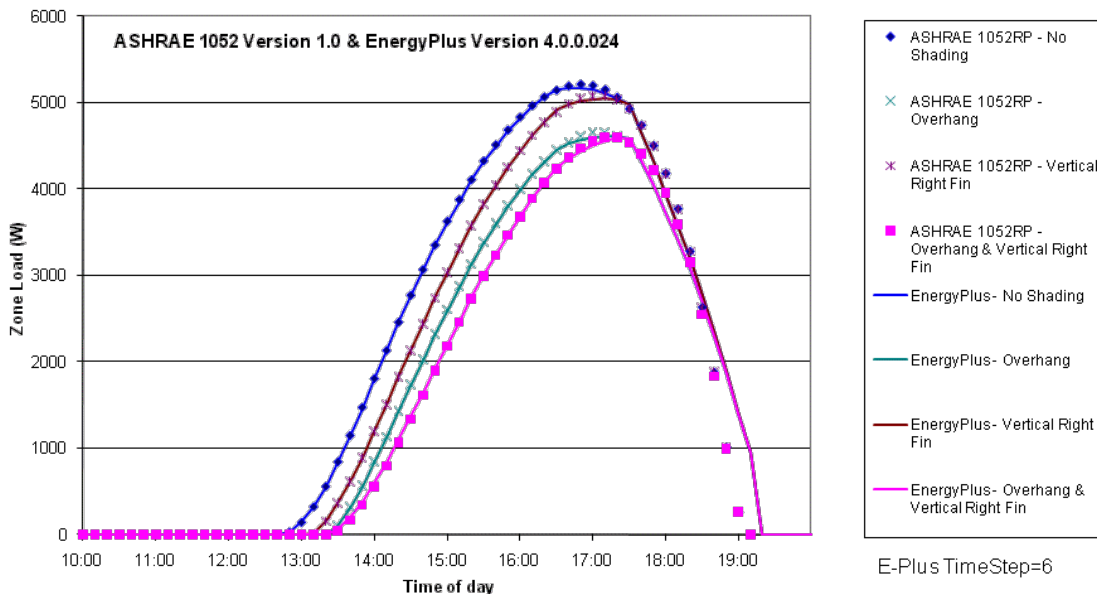

**Results for ASHRAE Analytical Test SolRadShade
Sunlit Area of 9 m² West Facing Window
with 0.6 m Overhang and/or 1.0 m Right Fin
Atlanta, August 21**

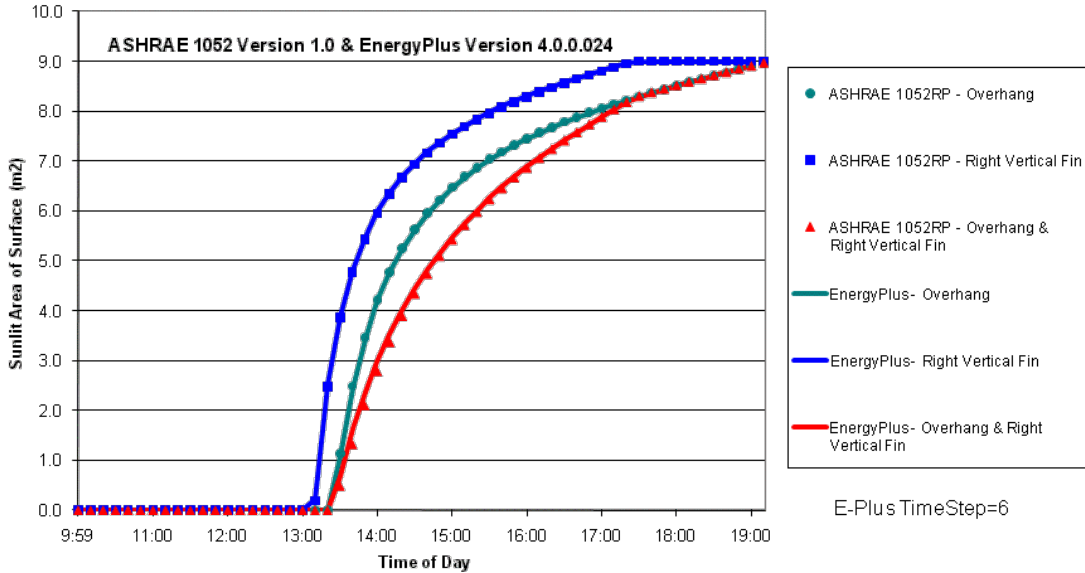

Test SolRadShade – Solar Radiation, Window Shading, West Facing

Test Parameter	Units	1052RP	EnergyPlus	% Diff
-With Overhang				
24-Hour Heat Gain	W-h/m ²	99446	101955	2.5%
Peak Load	W/m ²	4598	4616	0.3%
-With Fin				
24-Hour Heat Gain	W-h/m ²	111045	113850	2.5%
Peak Load	W/m ²	5081	5045	-0.7%
-With Overhang & Fin				
24-Hour Heat Gain	W-h/m ²	92847	95979	3.4%
Peak Load	W/m ²	4598	4593	-0.1%

EnergyPlus tracks the analytical results very closely except for the last couple of time increments late in the day. The reason for the differences during the late afternoon hours is again due to the interpolation of hourly solar data into 10 minute values as is shown in the chart below where use of the 10 minute weather file corrects this difference. Peak values for each situation also track very well.

**Results for ASHRAE Analytical Test SolRadShade
Sunlit Area of 9 m² West Facing Window
with 0.6 m Overhang and/or 1.0 m Right Fin
Atlanta, August 21**

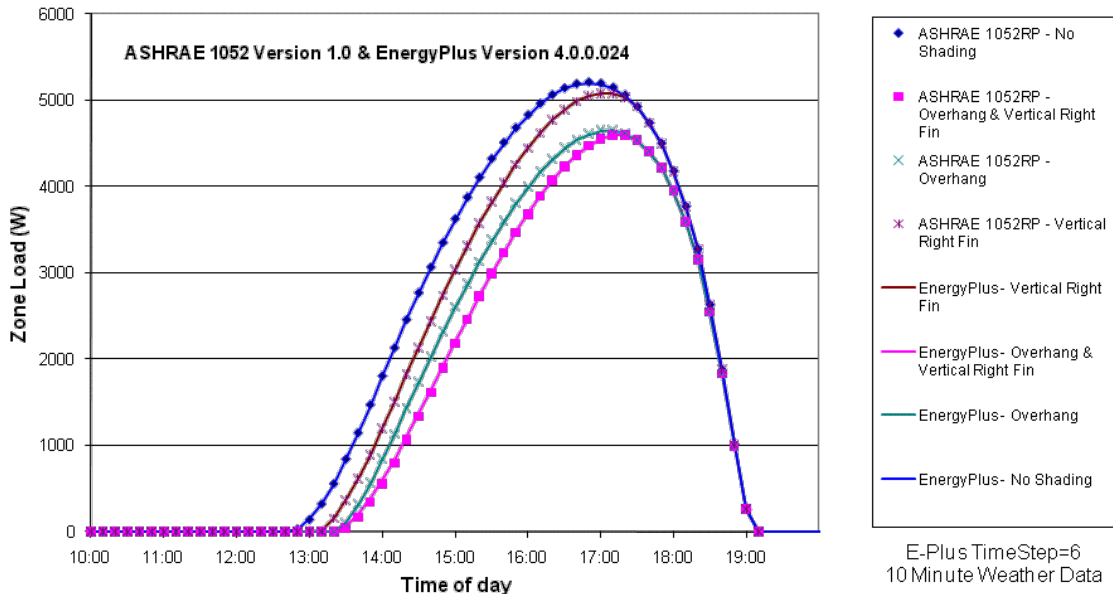

**Test SolRadShade – Solar Radiation, Window Shading, West Facing,
10 minute weather data**

Test Parameter	Units	1052RP	EnergyPlus	% Diff
-With Overhang				
24-Hour Heat Gain	W-h/m ²	99446	99112	-0.34%
Peak Load	W/m ²	4598	4650	1.13%
-With Fin				
24-Hour Heat Gain	W-h/m ²	111045	111006	-0.04%
Peak Load	W/m ²	5081	5083	0.04%
-With Overhang & Fin				
24-Hour Heat Gain	W-h/m ²	92847	93133	0.31%
Peak Load	W/m ²	4598	4598	0.00%

2.9 Test WinReveal – Window Reveal

This test is similar to the SolRadShade test described in the previous section except that the test surface is a 3m x 3m opaque wall with a 2m x 2m window which is setback into the window opening by 0.3m. The test surface here was chosen to be south facing. Shown below are resultant loads in the zone for two cases: one with a window that has a 0.3m reveal and one with a window that has no reveal (0.0m).

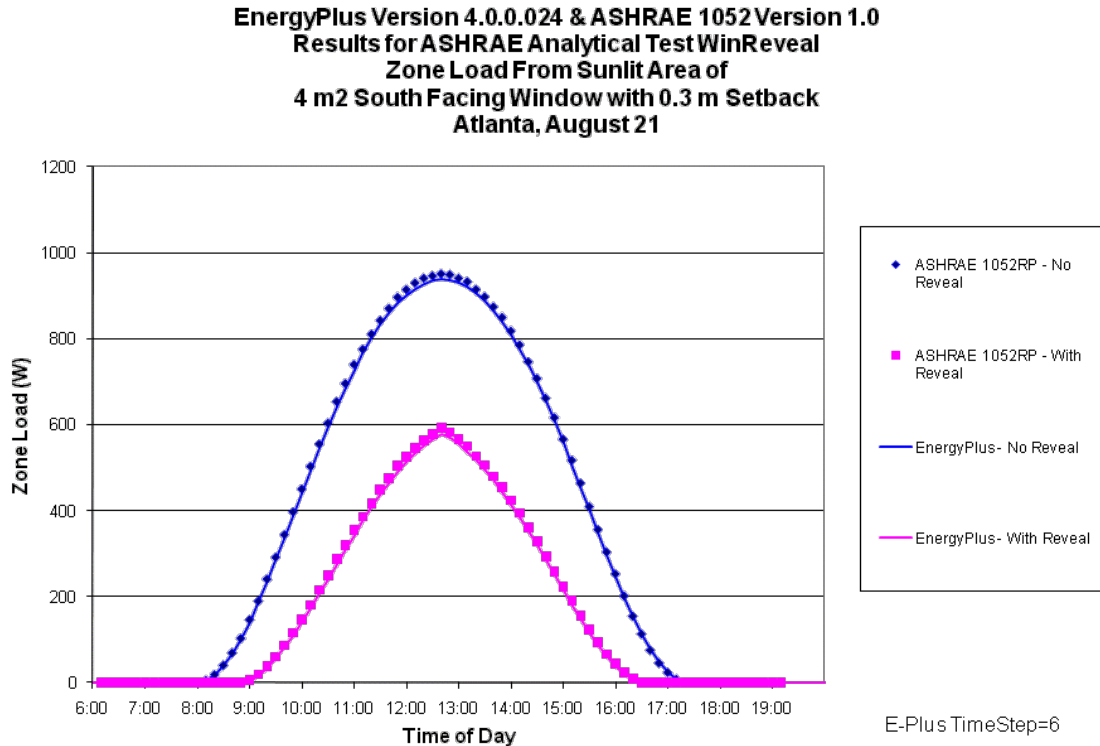

**EnergyPlus Version 4.0.0.024 & ASHRAE 1052 Version 1.0
ASHRAE Analytical Test WinReveal
Sunlit Area of 4 m² South Facing Window with 0.3 m Setback
Atlanta, August 21**

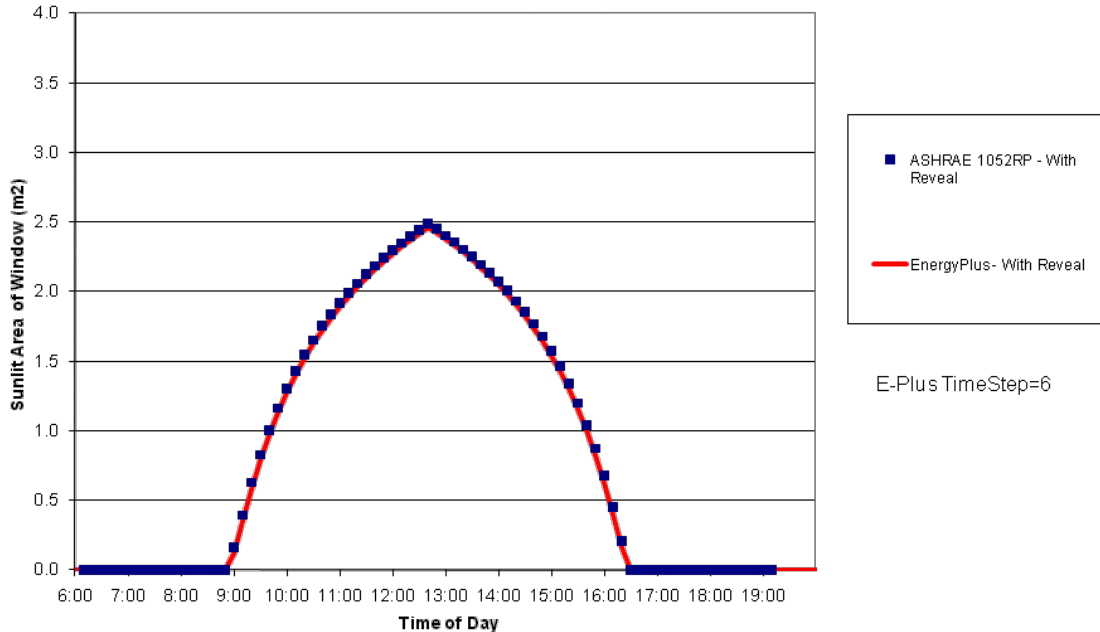

Test WinReveal – Window Reveal, South Facing				
Test Parameter	Units	1052RP	EnergyPlus	% Diff
-With Reveal				
24-Hour Heat Gain	W-h/m ²	13765	13375	-2.8%
Peak Load	W/m ²	592.1	577.8	-2.4%

The load curves for the no reveal case are very similar to those for the SolRadGlazing test presented and discussed in Section 2.7 where the peak load for EnergyPlus was slightly lower than the analytical result. The load curves for the window with reveal have a shape similar to those for the no reveal case except with reduced values due to the shading that the window setback creates. The sunlit area of the window for each time step as determined by EnergyPlus is almost identical to the analytical values.

2.10 Test IntSolarDist – Internal Solar Distribution

The test zone is 3m wide x 0.5m deep x 3m high. One of the 3m x 3m surfaces is chosen as the test surface and has a 1m x 1m window centered in the surface. The window has a 0.5m overhang and 0.5m fins on either side. This configuration allows solar radiation to impinge only on the internal surface of the wall opposite the window (see figure below). The surface opposite the window is assumed massless and no internal redistribution of solar radiation occurs. All other surfaces are of heavyweight construction and are assumed adiabatic. The heavyweight surfaces test to see if the program is redistributing the solar gains which for this test it should not. The inside and outside temperatures are held constant at 20°C. The location and date were set for Atlanta, August 21. The test surface with the window was chosen as east facing.

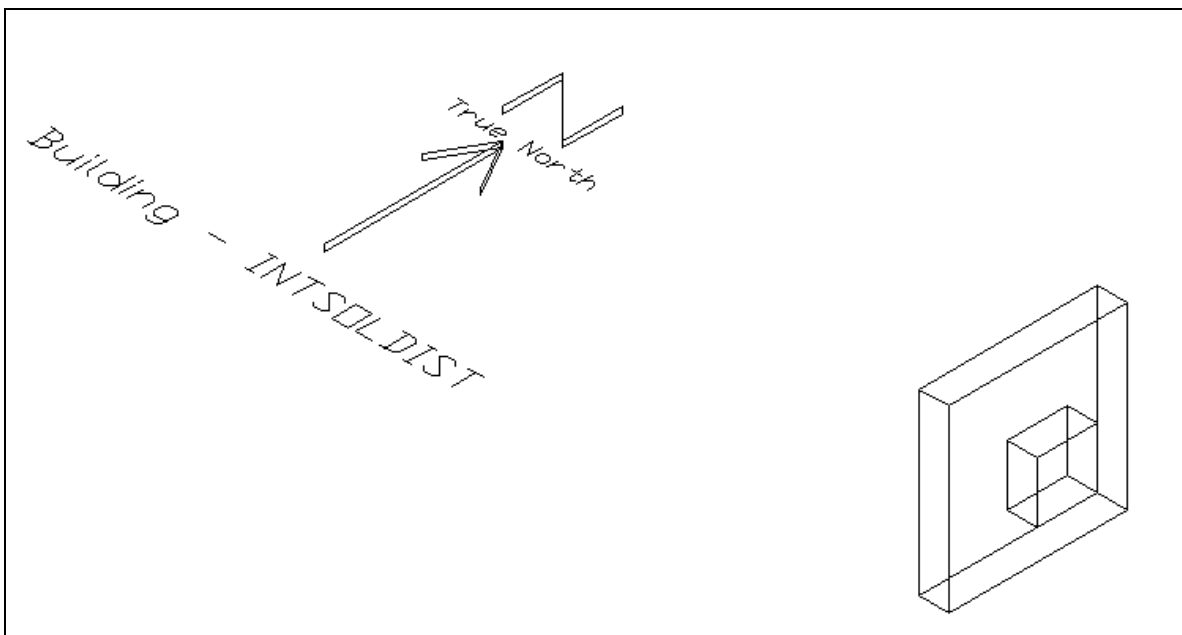

**EnergyPlus Version 4.0.0.024 & ASHRAE 1052 Version 1.0
Results for ASHRAE Analytical Test IntSolDist
Zone Load From Sunlit Area of 1 m² East Facing Window
with 0.5 m Overhang and 0.5 m Right & Left Fins
Atlanta, August 21**

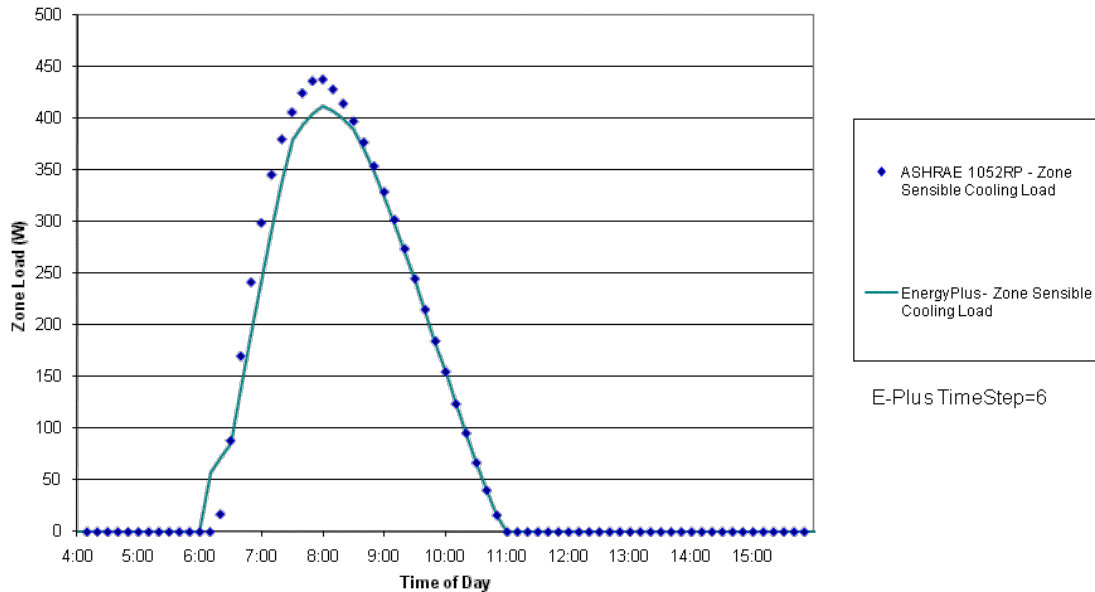

Test IntSolDist – Internal Solar Distribution, East Facing				
Test Parameter	Units	1052RP	EnergyPlus	% Diff
24-Hour Zone Load	W-h	7267	6942	-4.5%
Peak Load	W	438	412	-5.9%

The shape of the EnergyPlus zone load curve is similar to that for the analytical results except that there is a significant difference in peak values. The sunlit areas as shown below track the analytical results very closely. With EnergyPlus version 2.1.0.023 there was a slight change in results (<0.1% in 24-hour zone load) due to a change in the methodology for handling solar diffuse through a window which was completely reworked in EnergyPlus 2.1.0.012 and was changed from uniform interior distribution of transmitted diffuse solar to distribution based on approximate view factors between transmitting windows and zone heat transfer surfaces (CR 7237).

**EnergyPlus Version 4.0.0.024 & ASHRAE 1052 Version 1.0
Results for ASHRAE Analytical Test IntSolDist
Sunlit Area of 1 m² East Facing Window
with 0.5 m Overhang and 0.5 m Right & Left Fins
Atlanta, August 21**

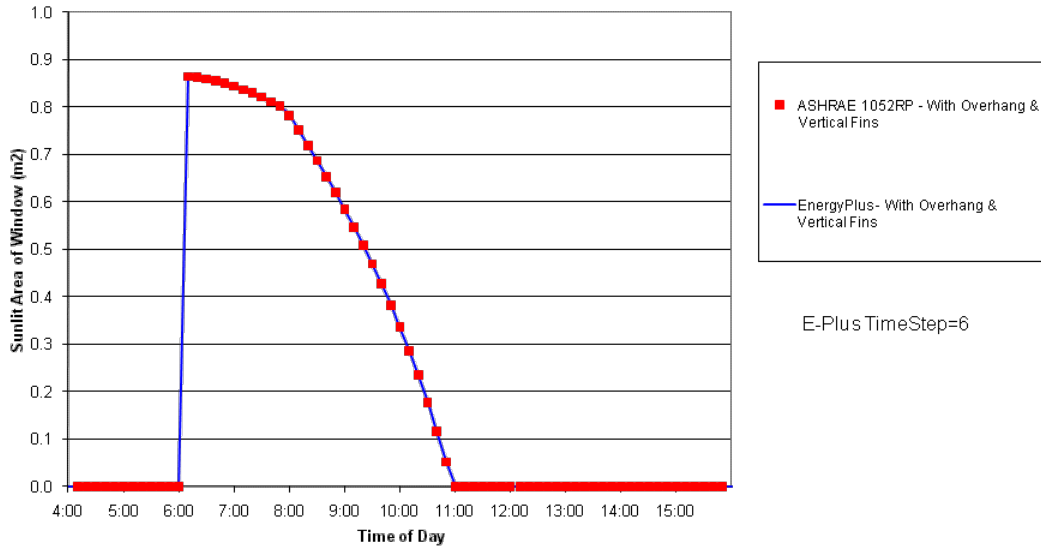

As indicated in the chart below, when the EnergyPlus simulation is rerun with a 10 minute weather file, almost perfect agreement is obtained with the analytical results.

**EnergyPlus Version 4.0.0.024 & ASHRAE 1052 Version 1.0
Results for ASHRAE Analytical Test IntSolDist
Zone Load From Sunlit Area of 1 m² East Facing Window
with 0.5 m Overhang and 0.5 m Right & Left Fins
Atlanta, August 21**

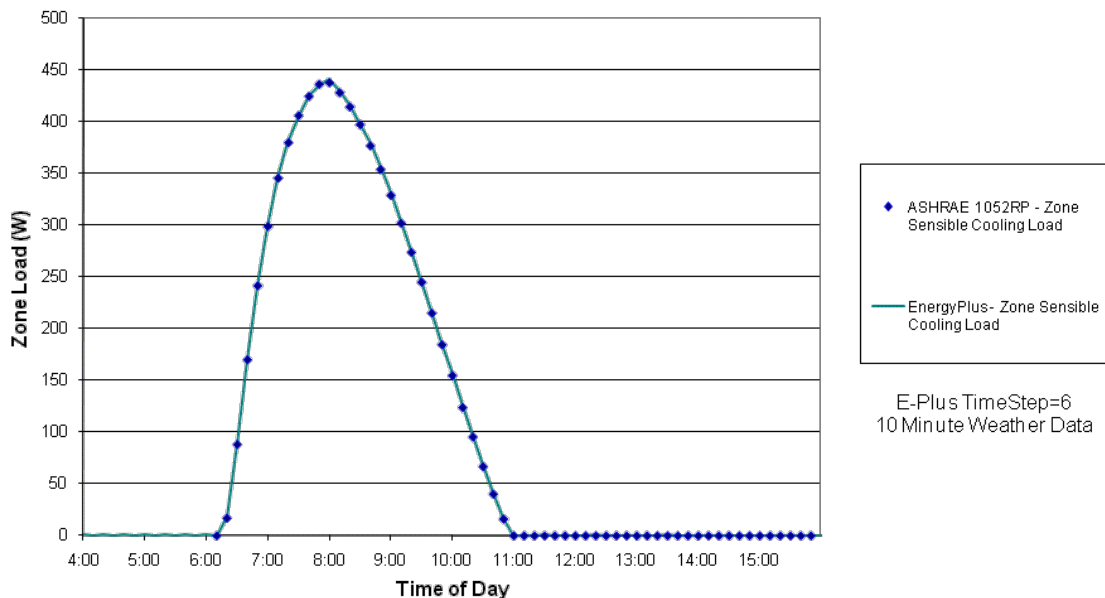

**Test IntSolDist – Internal Solar Distribution, East Facing,
10 minute weather data**

Test Parameter	Units	1052RP	EnergyPlus	% Diff
24-Hour Zone Load	W-h	7267	7340	1.0%
Peak Load	W	438	441	0.7%

2.11 Test Infiltration-1, Sensible Infiltration Load, Fixed Infiltration Rate

The test zone is again a cube measuring 3m x 3m x 3m with no windows. All surfaces are assumed adiabatic. The inside temperature is held constant at 20°C and outside temperature is constant at 10°C. Infiltration occurs at a constant rate of 0.5 m³/s.

Test Parameter	Units	1052RP	EnergyPlus	% Diff
Zone Load	W-h	6305	6270	-0.6%
Outside Air Density	Kg/ m ³	1.243	1.237	-0.5%
Mass Flow Rate of Air	Kg/s	0.622	0.619	-0.5%
Inside Air Enthalpy	J/kg dry air	31791		
Outside Air Enthalpy	J/kg dry air	21648	21530	-0.5%

EnergyPlus results for Test Infiltration-1 are very close to ASHRAE 1052 analytical results.

2.12 Test Infiltration-2, Stack Effect

The objective of this test is to test the treatment of infiltration under the pressure difference due to density and height differences resulting from fixed openings in the building fabric. This is done for a single zone with openings at high and low levels. The test zone is a tall cubic measuring 3m x 3m x 10m. Two 0.5m x 0.2m openings are placed symmetrically at the top and bottom of the external walls. All surfaces are adiabatic. The inside temperature is held constant at 20°C and outside temperature is constant at 10°C. The inside and outside humidity ratios are held constant at the same value.

The modeling of this test with EnergyPlus required the use of the AIRFLOW NETWORK module. The EnergyPlus AIRFLOW NETWORK module allows a wall opening through which air flows to be modeled as a SIMPLE OPENING, DETAILED OPENING or SURFACE CRACK. The SURFACE CRACK method was chosen for this test because the formulas used by EnergyPlus for the SURFACE CRACK method are the same as those described in the test documentation for the analytical solution for this test case. EnergyPlus does not calculate the height of the neutral pressure zone. This was calculated instead by hand using the equation in the test documentation.

Test Parameter	Units	1052RP	EnergyPlus	% Diff
Zone Load	W-h	0.1489	0.1505	1.10%
Mass Flow Rate of Air	Kg/s	1510.3	1519.6	0.62%
Height of Neutral Pressure Zone	m	4.9345	4.9311	-0.07%

The EnergyPlus results for Test Infiltration-2 are very close to the ASHRAE 1052-RP analytical results

2.13 Test ExtLWRad – External Long Wave Radiation

The test zone is a cube measuring 3m x 3m x 3m with no windows. The external surface to be tested is a horizontal roof made of a single layer with thickness of 0.1m, thermal conductivity of 1.00 W/m-K and surface emissivity of 0.9. All other surfaces are adiabatic and have no thermal mass. The effects of solar irradiation, internal long wave radiation, infiltration, and internal heat gains are eliminated. Inside and outside temperatures are fixed at 20°C. One of the 1052RP inputs required for this test is the sky temperature in °C. The sky temperature in EnergyPlus cannot be fixed at a certain temperature, therefore EnergyPlus was run first using the above input parameters to determine the resulting sky temperature and inside and outside surface convection coefficients. EnergyPlus gave the following results:

Inside surface convection coefficient = 4.04 W/m²-K
Outside surface convection coefficient = 1.352 W/m²-K
Sky temperature = 7.552°C

The ASHRAE 1052RP toolkit was then use to simulate the ExtLWRad test with the input parameters set to be the same as those used by EnergyPlus. The comparative results are presented below.

Test ExtLWRad: External Long Wave Radiation

Test Parameter	Units	1052RP	EnergyPlus	% Diff
Heat Flux	W/m ²	18.78	24.31	29.5%
Zone Load	W-h	168.98	218.78	29.5%
				Delta
Inside Surface Temperature	C	15.35	16.80	1.45C
Outside Surface Temperature	C	13.48	14.37	0.90C
Inside Convection Coefficient	W/m ² -K	4.040	4.040	
Outside Convection Coefficient	W/m ² -K	1.352	1.352	
Sky Temperature	C	7.552	7.552	

Note: Convection coefficients and sky temperature were taken from EnergyPlus and entered into 1052RP Toolkit software

Zone Load = Heat Flux x 9m² surface area

The reason for these differences is uncertain, but may be due to differences in modeling approach.

2.14 Test IntLWRad – Interior Long Wave Radiation

The test zone is a building of 3m x 3m cross-section and varying length where $L=3 \times AR$ where AR is the aspect ratio. There are no windows. One of the 3m x 3m surfaces is selected as an external surface and the other surfaces are adiabatic. The test surface is of lightweight construction. The AR is varied from 1 to 2 to 5 to 10 to 20. The inside and outside temperatures are held constant at 20°C and 40°C respectively. Three different sets of surface emissivities are tested. Resulting interior surface temperatures for each set of emissivities and varying AR are presented below.

2.14.1 Test 1 –Ext. Surf. Emis. = 0.9, Oppos. Surf. Emis. = 0.1, Other Surf. Emis. = 0.3

EnergyPlus Version 4.0.0.024 & ASHRAE 1052 Version 1.0
ASHRAE Analytical Test IntLWRad-Test 1
Exterior Wall Surface Temperature versus Aspect Ratio
Building of 3mx3m Cross-Section of Varying Length (L=3xAR)
Ext. Surf. Emis.=0.9, Oppos. Surf. Emis.=0.1, Other Surf. Emis.=0.3
Outdoor Temp=40C, Indoor Temp=20C

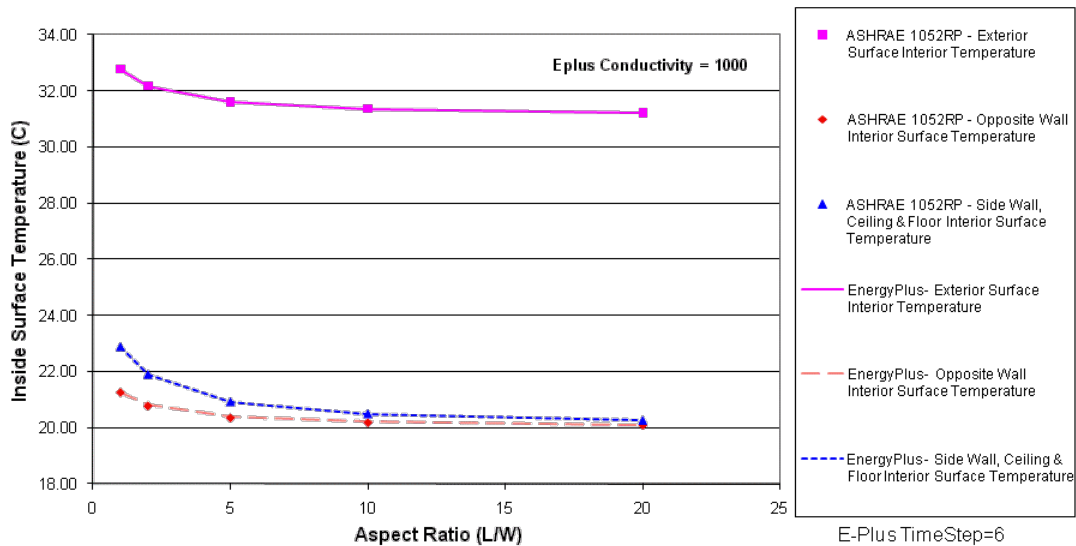

Excellent agreement is obtained between the two programs. For the EnergyPlus simulations, the ConvectionCoefficients object was used to force the inside convection coefficient to be the same value for all surfaces for a given aspect ratio in order to conform with the 1052 toolkit specification.

EnergyPlus Version 4.0.0.024 & ASHRAE 1052 Version 1.0
ASHRAE Analytical Test IntLWRad-Test 1
Zone Load versus Aspect Ratio
Building of 3mx3m Cross-Section of Varying Length (L=3xAR)
Ext. Surf. Emis.=0.9, Oppos. Surf. Emis.=0.1, Other Surf. Emis=0.3
Outdoor Temp=40C, Indoor Temp=20C

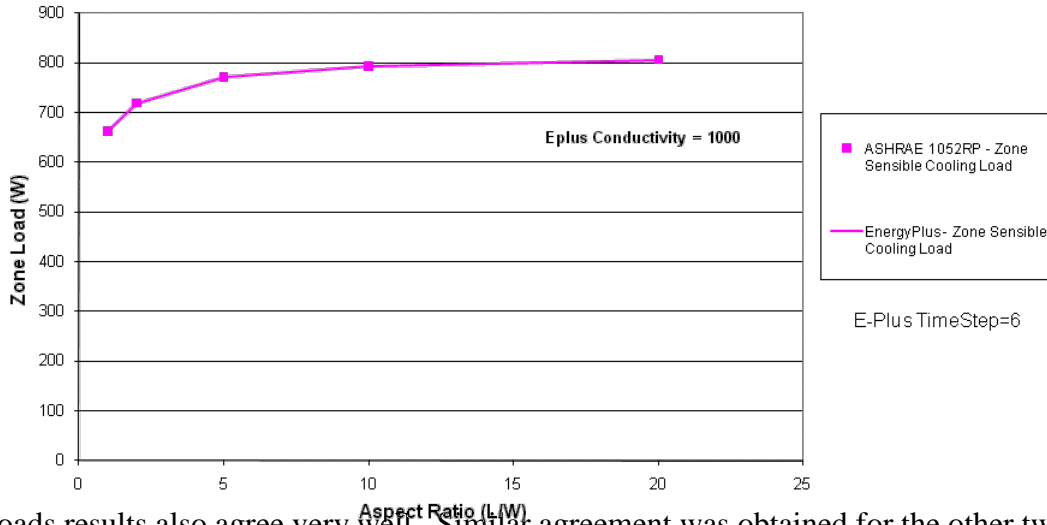

Zone loads results also agree very well. Similar agreement was obtained for the other two tests as indicated below.

Test IntLWRad - Interior Long Wave Radiation, Test 1				
Test Parameter	Units	1052-RP	EnergyPlus	% Diff
-Exterior Wall Interior Temp				
AP=1	C	32.78	32.78	-0.01%
AP=2	C	32.18	32.17	-0.01%
AP=5	C	31.61	31.61	-0.02%
AP=10	C	31.37	31.36	-0.02%
AP=20	C	31.23	31.22	-0.02%
-Opposite Wall Interior Temp				
AP=1	C	21.26	21.26	0.00%
AP=2	C	20.78	20.82	0.18%
AP=5	C	20.36	20.40	0.19%
AP=10	C	20.19	20.21	0.13%
AP=20	C	20.10	20.11	0.07%
-Other Surfaces Interior Temp				
AP=1	C	22.89	22.89	-0.01%
AP=2	C	21.90	21.89	-0.03%
AP=5	C	20.93	20.92	-0.01%
AP=10	C	20.50	20.50	0.00%
AP=20	C	20.26	20.26	0.00%
-Zone Sensible Cooling Load				
AP=1	W-h	663.7	663.4	-0.04%
AP=2	W-h	719.6	719.1	-0.07%
AP=5	W-h	771.5	771.2	-0.04%
AP=10	W-h	794.2	793.9	-0.03%
AP=20	W-h	806.7	806.3	-0.04%

2.14.2 Test 2 –Ext. Surf. Emis. = 0.9, All Other Surf. Emis. = 0.1

**EnergyPlus Version 4.0.0.024 & ASHRAE 1052 Version 1.0
 ASHRAE Analytical Test IntLWRad-Test 2
 Exterior Wall Surface Temperature versus Aspect Ratio
 Building of 3mx3m Cross-Section of Varying Length (L=3xAR)
 Ext. Surface Emis=0.9, All Other Surfaces Emis=0.1
 Outdoor Temp=40C, Indoor Temp=20C**

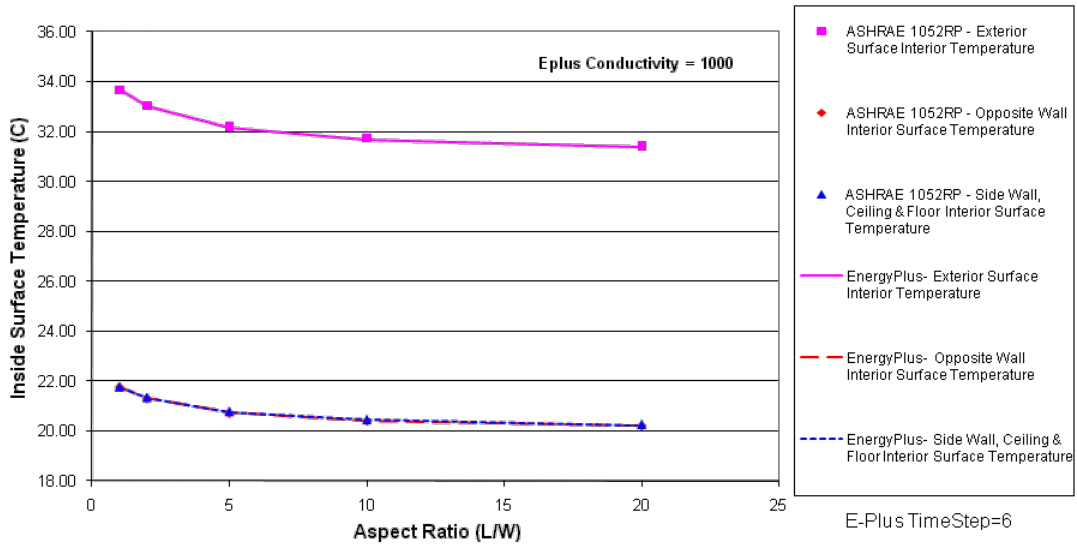

**EnergyPlus Version 4.0.0.024 & ASHRAE 1052 Version 1.0
 ASHRAE Analytical Test IntLWRad-Test 2
 Zone Load versus Aspect Ratio
 Building of 3mx3m Cross-Section of Varying Length (L=3xAR)
 Ext. Surface Emis=0.9, All Other Surfaces Emis=0.1
 Outdoor Temp=40C, Indoor Temp=20C**

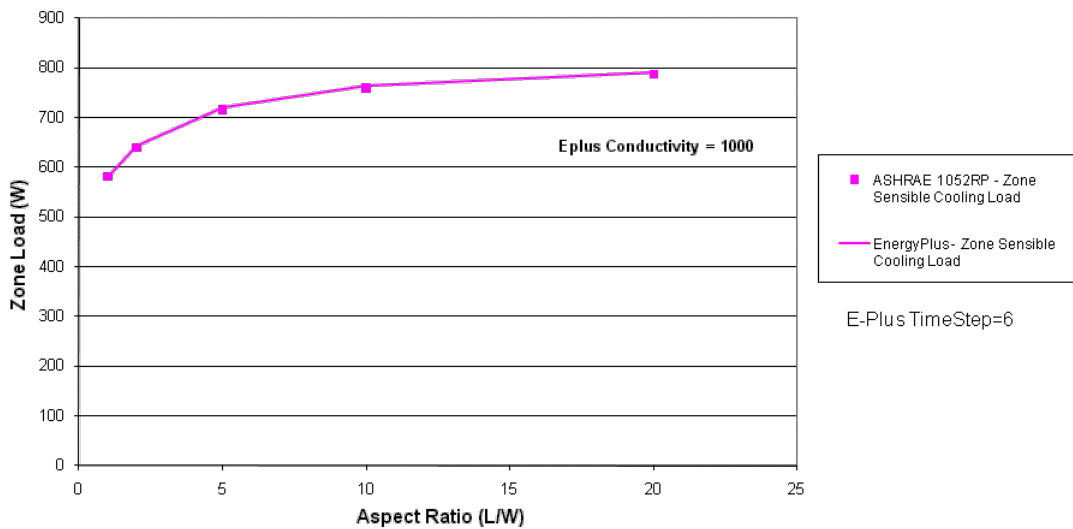

Test IntLWRad - Interior Long Wave Radiation, Test 2				
Test Parameter	Units	1052-RP	EnergyPlus	% Diff
-Exterior Wall Interior Temp				
AP=1	C	33.67	33.67	-0.01%
AP=2	C	33.04	33.00	-0.13%
AP=5	C	32.21	32.15	-0.19%
AP=10	C	31.74	31.68	-0.20%
AP=20	C	31.44	31.38	-0.20%
-Opposite Wall Interior Temp				
AP=1	C	21.76	21.76	0.00%
AP=2	C	21.29	21.30	0.03%
AP=5	C	20.72	20.73	0.06%
AP=10	C	20.42	20.43	0.04%
AP=20	C	20.23	20.23	0.03%
-Other Surfaces Interior Temp				
AP=1	C	21.76	21.76	0.00%
AP=2	C	21.34	21.31	-0.11%
AP=5	C	20.77	20.75	-0.11%
AP=10	C	20.45	20.44	-0.07%
AP=20	C	20.25	20.24	-0.04%
-Zone Sensible Cooling Load				
AP=1	W-h	582.0	581.8	-0.03%
AP=2	W-h	640.0	643.1	0.50%
AP=5	W-h	716.6	721.5	0.68%
AP=10	W-h	759.9	764.8	0.65%
AP=20	W-h	787.2	792.3	0.64%

2.14.3 Test 3 –All Surf. Emis. = 0.9

EnergyPlus Version 4.0.0.024 & ASHRAE 1052 Version 1.0
ASHRAE Analytical Test IntRad-Test 3
Exterior Wall Surface Temperature versus Aspect Ratio
Building of 3mx3m Cross-Section of Varying Length (L=3xAR)
All Surfaces Emis=0.9
Outdoor Temp=40C, Indoor Temp=20C

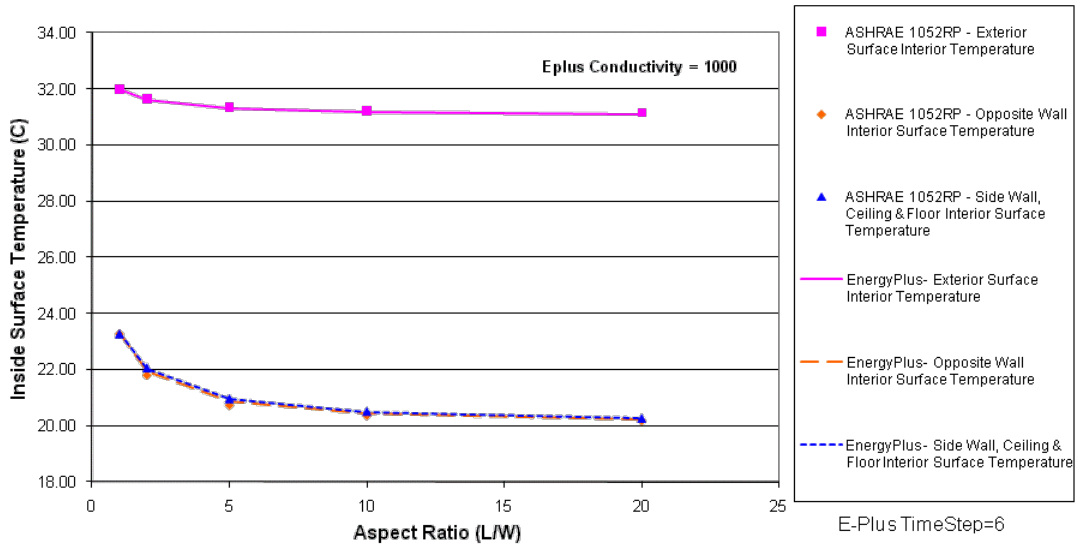

EnergyPlus Version 4.0.0.024 & ASHRAE 1052 Version 1.0
ASHRAE Analytical Test IntrRad-Test 3
Zone Load versus Aspect Ratio
Building of 3mx3m Cross-Section of Varying Length (L=3xAR)
All Surfaces Emis=0.9
Outdoor Temp=40C, Indoor Temp=20C

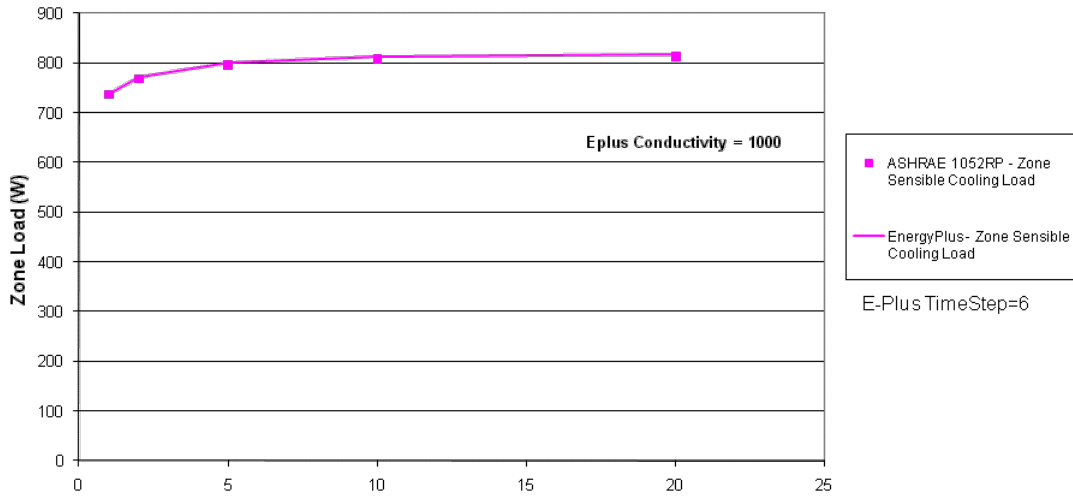

Test Parameter	Units	1052-RP	EnergyPlus	% Diff
Test IntLWRad - Interior Long Wave Radiation, Test 3				
-Exterior Wall Interior Temp				
AP=1	C	31.99	31.98	-0.02%
AP=2	C	31.65	31.61	-0.13%
AP=5	C	31.35	31.29	-0.18%
AP=10	C	31.22	31.16	-0.19%
AP=20	C	31.15	31.09	-0.20%
-Opposite Wall Interior Temp				
AP=1	C	23.29	23.29	0.00%
AP=2	C	21.82	21.95	0.60%
AP=5	C	20.74	20.87	0.63%
AP=10	C	20.37	20.45	0.41%
AP=20	C	20.19	20.23	0.23%
-Other Surfaces Interior Temp				
AP=1	C	23.29	23.29	-0.01%
AP=2	C	22.07	22.03	-0.22%
AP=5	C	20.97	20.94	-0.16%
AP=10	C	20.51	20.49	-0.09%
AP=20	C	20.26	20.25	-0.05%
-Zone Sensible Cooling Load				
AP=1	W-h	737.0	736.7	-0.04%
AP=2	W-h	768.3	771.3	0.40%
AP=5	W-h	796.0	800.4	0.56%
AP=10	W-h	807.6	812.2	0.57%
AP=20	W-h	813.7	818.5	0.60%

2.15 Test IntHeatGain – Internal Heat Gains, Convective and Radiative

The test zone is a 3m x 3m x 3m cube with no windows. All surfaces of the zone are single layer and of the same construction and are adiabatic. The inside temperature is held constant at 20°C. A 2700 W internal load is turned on for 168 hours and then is turned off. Tests are run for three different situations assuming the internal loads are 100% radiative, 50% radiative and 0% radiative (100% convective).

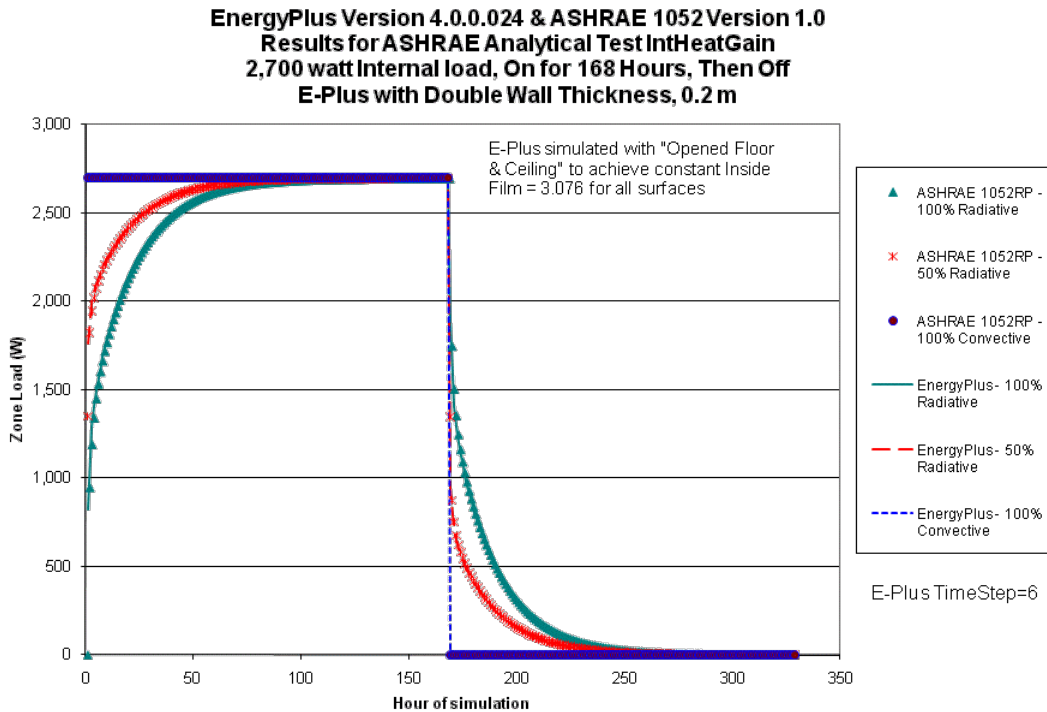

EnergyPlus Version 4.0.0.024 & ASHRAE 1052 Version 1.0
 Results for ASHRAE Analytical Test IntHeatGain
 2,700 watt Internal load, On for 168 Hours, Then Off
 E-Plus with Double Wall Thickness, 0.2 m

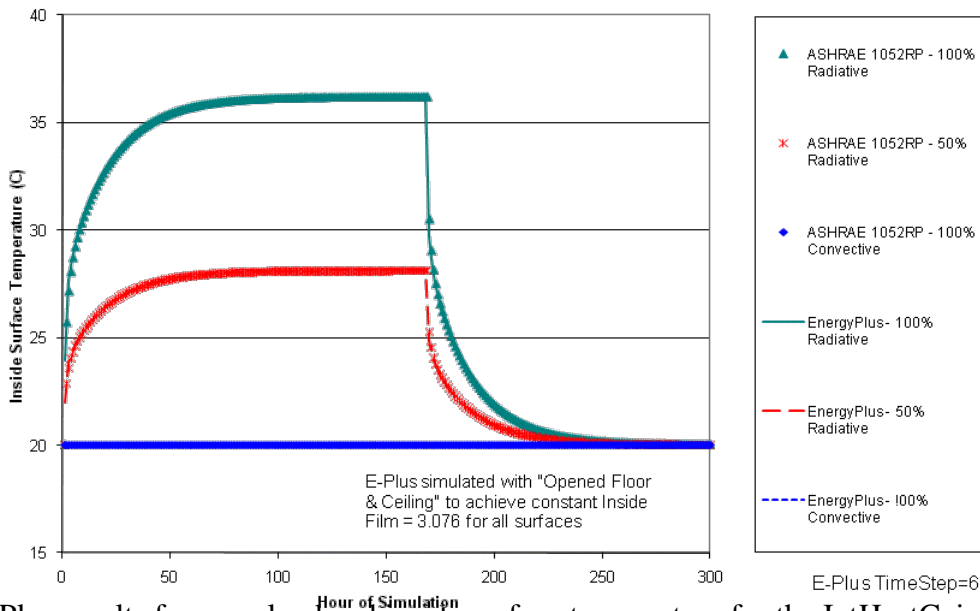

EnergyPlus results for zone load and inside surface temperature for the IntHeatGain test are almost identical to the analytical results.

Test IntHeatGain - Internal Heat Gains				
Test Parameter	Units	1052-RP	EnergyPlus	% Diff
-100% Radiative				
24-Hour Zone Load	W-h	452,846	453,596	0.17%
Peak Load	W-h	2,695	2,700	0.16%
-50% Radiative				
24-Hour Zone Load	W-h	453,069	453,599	0.12%
Peak Load	W-h	2,697	2,700	0.12%
-100% Convective				
24-Hour Zone Load	W-h	453,600	453,608	0.00%
Peak Load	W-h	2,700	2,700	0.00%

2.16 Test GrdCoup – Ground Coupling, Slab-on-Grade Floor

The test zone is again a cube with internal dimensions of 3m x 3m x 3m with no windows. All surfaces except the floor are adiabatic. The effects of solar irradiation, long wave radiation and infiltration are eliminated. The floor and ground are treated as a uniform semi-infinite slab. The inside air temperature is constant at 25°C while the ground temperature is constant at 2°C.

To handle ground coupling problems with slab-on-grade floors, EnergyPlus requires the running of a separate auxiliary program called Slab. As input this program requires the properties of the slab and soil, thickness of the slab, the average inside monthly temperature, insulation details and properties, area-to-perimeter ratio of the slab, indoor combined radiative and convective heat transfer coefficient, etc. The Slab program also requires an hourly weather file which it uses to calculate the deep ground temperature. The program calculates the resulting monthly slab/ground interface temperatures for the core and perimeter area of the slab and also the area weighted average temperature of the slab/ground interface. These monthly temperatures at the exterior of the slab surface are then input to the EnergyPlus whole building simulation program using the GroundTemperatures object where the heat flux of the floor is used to perform the heat balance within the zone each timestep.

Unlike the other tests that are part of the 1052 Toolkit, the GrdCoup test does not generate a weather file that can be used by the test program. An EPW weather file in EnergyPlus format had to be generated separately for use with the Slab program. In doing this it was assumed that the outdoor dry-bulb temperature was held constant each hour and was set equal to the outside ground temperature (2C) that was specified for the 1052 Toolkit input, and all solar values were set to zero. The results of EnergyPlus versus the 1052 Toolkit results are presented below.

Test Parameter	Units	1052RP	EnergyPlus	% Diff
Inside Floor Temperature	C	12.00	6.27	
Zone Load	W	110.9	159.8	44.1%

For EnergyPlus version 1.2.2.030, the Slab program was significantly modified to add new user inputs and to refine the autogridding scheme. However, the EnergyPlus results are still significantly different from the ASHRAE 1052 results. Possible reasons include

- 1) The creation of an EnergyPlus weather file may be causing some differences
- 2) The 1052-RP specification calls for the ground surface temperature to be the same as the deep ground temperature. The EnergyPlus Slab program requires that the distance from the edge of the slab to the domain edge be specified. No value was given for this parameter in the 1052-RP specification. It was assumed to be 10m.
- 3) The EnergyPlus Slab program requires the user to specify the thickness of the slab. None was given in the specification. It was assumed to be 0.13m.

- 4) The EnergyPlus Slab program requires that the material properties of the slab and soil be specified. None were given in the specification except for the 1.0 W/m-K slab conductivity. It was assumed that the density of the slab and soil was 2200 kg/m³ and the specific heat of the slab and soil was 670 J/kg-K.
- 5) The documentation for this test states that “The floor is rectangular and is bounded (but not penetrated) on each side by four equal width external walls. It is assumed that the effect of the walls is to change the ground/slab surface temperature linearly over their thickness. The walls have a finite conductance but its actual value is unimportant.” This boundary condition is not simulated by the Slab program, which assumes that entire top surface of the slab is exposed to the zone air temperature, and that all of the ground is exposed to the outdoor conditions. The wall thickness in the toolkit was to 0.1mm to minimize the impact of this boundary condition.

Further investigation of these issues will be done as part of work on a more extensive ground coupling test suite.

3 ENERGYPLUS PROBLEMS UNCOVERED WHILE USING ASHRAE 1052-RP TOOLKIT

During the process of using the ASHRAE 1052-RP Toolkit to test early versions of EnergyPlus, several significant differences were identified when comparing the EnergyPlus results to that of the toolkit. Each of these is discussed further in this section with the eventual resolution of the problem.

3.1 Inverted Coordinates for Shade Fins

As was described in Section 2.8, a series of SolRadShade cases test a program's ability to handle shading of windows caused by horizontal overhangs and vertical fins. A schematic of the SolRadShade test model for a south facing window with semi-infinite overhang and right fin is shown in Figure 1 below.

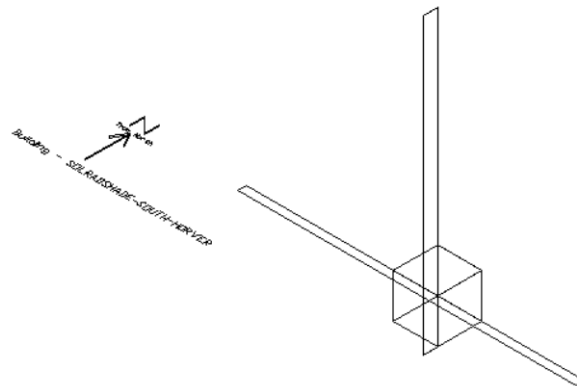

Figure 1 View of SolRadShade Test Model with South Facing Window and Semi-Infinite Overhang and Right Fin

When the SolRadShade test for this configuration was simulated with EnergyPlus version 1.0.0.011, the results shown below in Figure 2 were obtained.

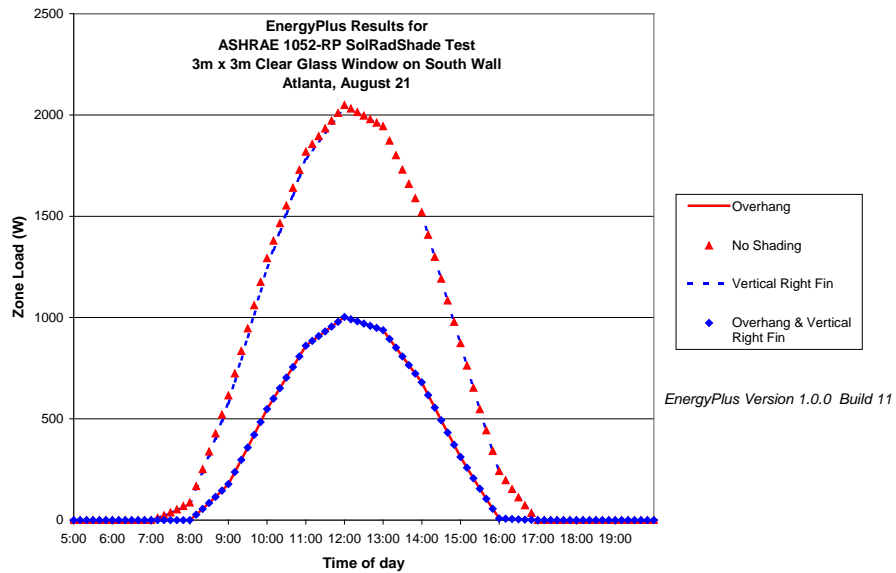

Figure 2 Results from ASHRAE 1052-RP SolRadShade Test – Window Solar Gain Indicating Error with Shade Fin Calculation

The two cases with overhangs showed the expected reduction in zone load versus the “No Shading” case but the test with only the right fin present showed very little change from the “No Shading” case. This obviously was not right. Further searching into the reason why this was happening revealed that EnergyPlus was not setting the coordinates of the fin correctly. EnergyPlus had internally switched the length and width dimensions of the vertical fin which inverted the fin coordinates. This put the long dimension of the fin horizontally along the ground and the short dimension of the fin extending vertically upward, causing very little shading. This is an error that propagated from BLAST (Building Systems Laboratory, 1999) where the EnergyPlus shading calculation code originated. Once a correction was made to the EnergyPlus code, the expected results as shown in Figure 3 were obtained.

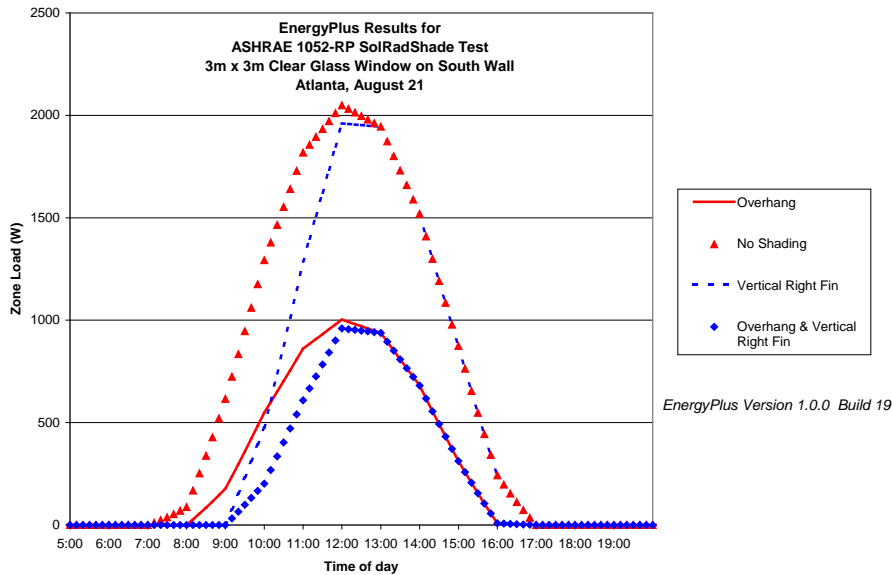

Figure 3 Results from ASHRAE 1052-RP SolRadShade Test – Window Solar Gain with Shade Fin Problem Corrected

Figure 4 below shows the SolRadShade test results with the latest release of EnergyPlus along with the corresponding 1052-RP analytical results. These EnergyPlus results also include the impact of a solar time shift error that was corrected and is further discussed in Section 3.3.

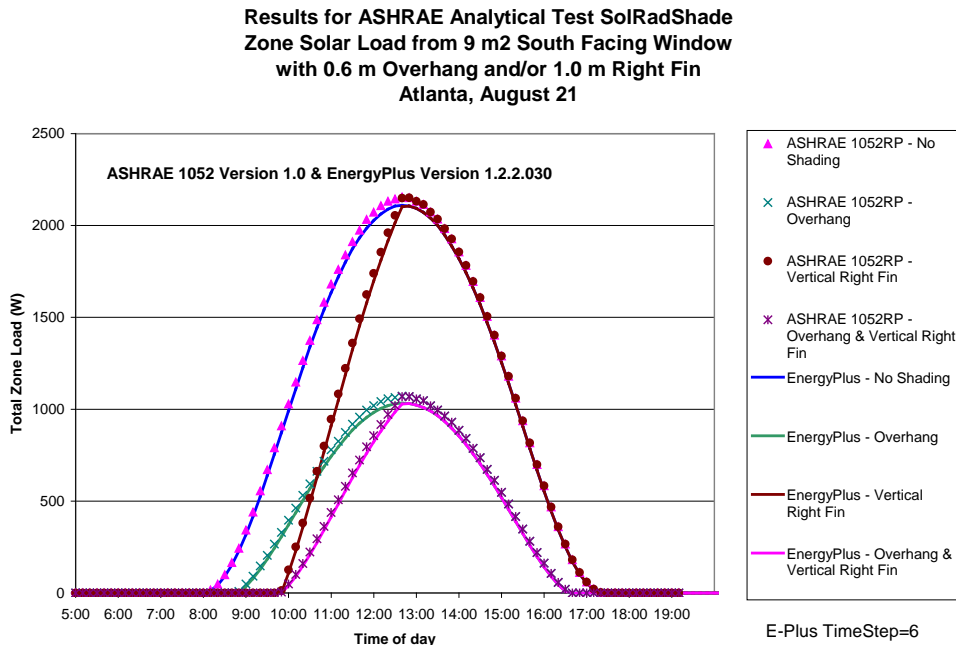

Figure 4 Results from ASHRAE 1052-RP SolRadShade Test – Window Solar Gain with Shade Fin Problem and Solar Time Shift Problem Corrected

3.2 Sunlit Areas of Surfaces

With early versions of EnergyPlus the sunlit area calculations for shaded surfaces such as windows were done once each hour at the beginning of the hour and then were assumed constant for the rest of the hour. This was done to increase the speed of an EnergyPlus simulation. When the results of the sunlit area calculations using this approach were compared to 1052-RP analytical results however (see Figure 5), it was discovered that EnergyPlus was predicting the sunlit area for this test to be 7.2% higher than the analytical result on a daily basis. In EnergyPlus 1.0.1.010 the sunlit area calculation was changed to occur at the beginning of every time step rather than only once each hour. This reduced the difference between EnergyPlus and 1052-RP to less than 1% as shown in Figure 6.

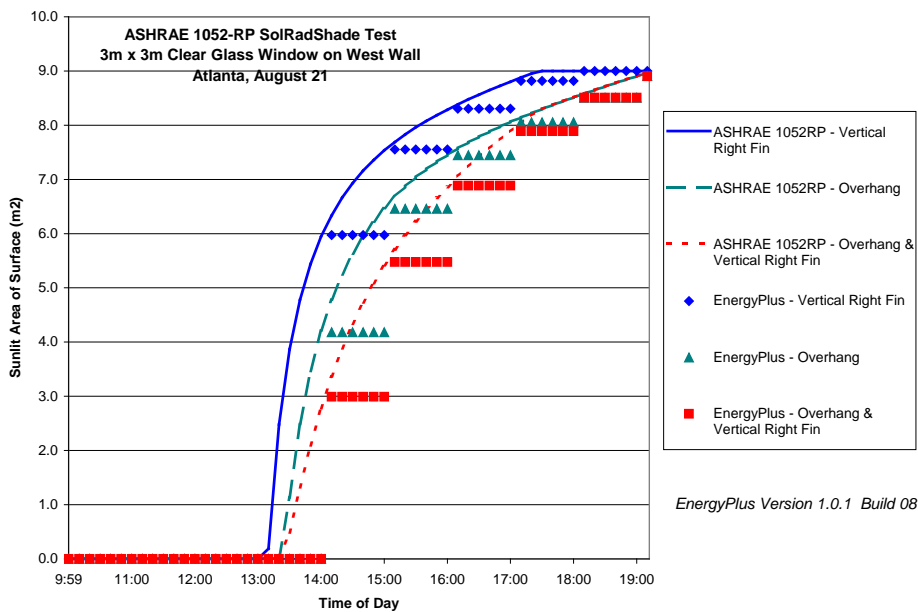

Figure 5 Results from ASHRAE 1052-RP SolRadShade Test – EnergyPlus Window Sunlit Area Calculated Once Each Hour

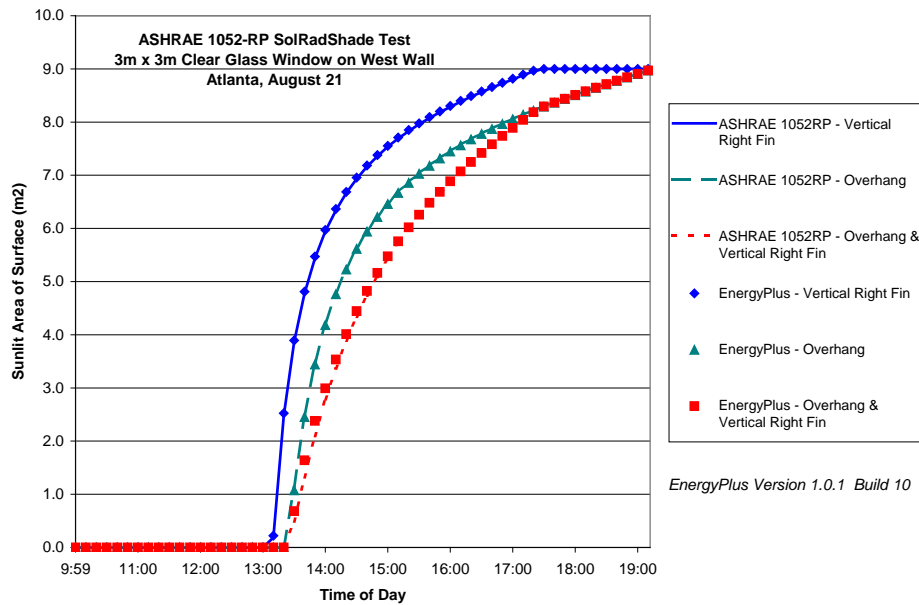

Figure 6 Results from ASHRAE 1052-RP SolRadShade Test – EnergyPlus Window Sunlit Area Calculated for each Timestep

3.3 Solar Time Shift

When comparing the results of early versions of EnergyPlus with the results of various 1052-RP tests involving solar gain, it was noticed that there was a time shift between the simulated and analytical results (see Figure 7). Initially this was thought to be a daylight savings time error, but that was ruled out. It was determined that the problem was attributed to the manner in which hourly weather data was being interpolated for sub-hourly time steps. Data recorded on weather files are in one hour increments where for solar radiation the values are the total or average for the hour. Prior to EnergyPlus 1.0.1 Build 8 the solar radiation value taken from the weather file was assumed to be for the beginning of the hour and interpolation was then used to get the solar radiation for the sub-hourly time steps during the hour. This approach resulted in the time shift shown in Figure 7. Things improved when a “half” solar radiation interpolation technique was adopted where the solar radiation value read from the weather file was assumed to be at the half-hour point and then interpolated to get the values at the other time steps within the hour. This technique resulted in a very good correlation pattern with the 1052-RP toolkit results as shown in Figure 8 but the peak cooling load for EnergyPlus was 4.6% lower than that predicted by 1052-RP.

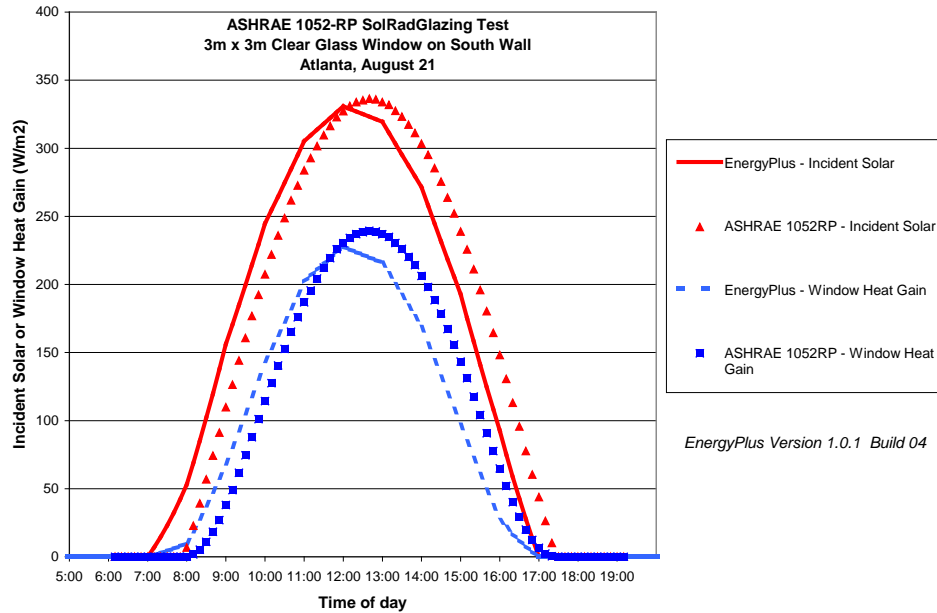

Figure 7 Results from ASHRAE 1052RP SolRadGlazing Analytical Test - Window Solar Gain, Atlanta, August 21, South Facing Clear Single-Pane Glass Showing Time Shift in Results

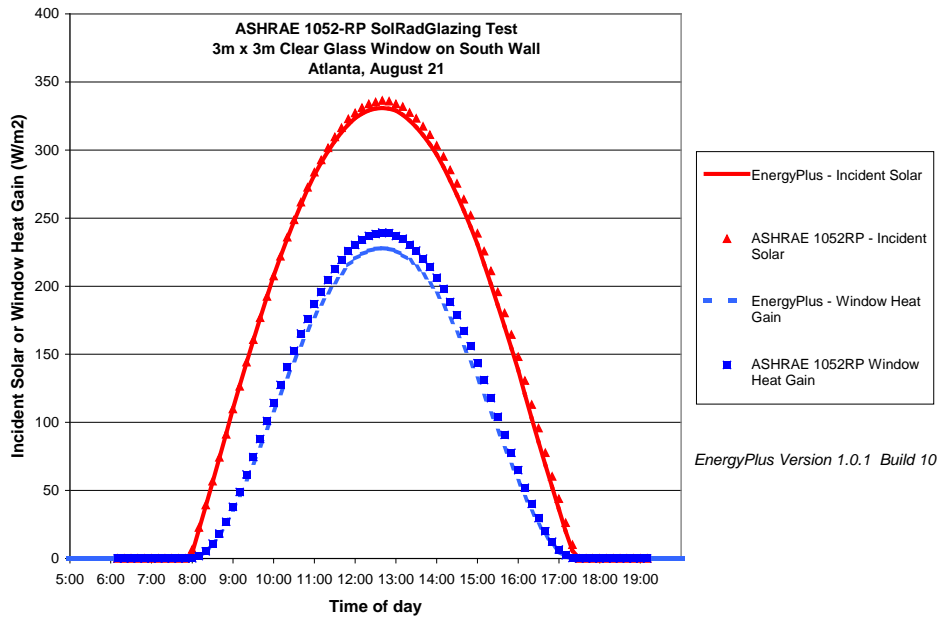

Figure 8 Results from ASHRAE 1052RP SolRadGlazing Analytical Test - Window Solar Gain, Atlanta, August 21, South Facing Clear Single-Pane Glass with Solar Time Shift Corrected

3.4 Underestimating Peak Cooling Loads with Windows

As is evidenced by the EnergyPlus results presented in Figure 8 above, for most of the 1052-RP tests with windows EnergyPlus version 1.0 releases and earlier were predicting peak cooling loads that were smaller than the analytical results. Some of this difference got resolved when the EnergyPlus algorithms for handling solar transmittance through glass were updated. Algorithm changes were made to the window calculation of transmittance and reflectance versus angle of incidence for a single glass layer to correspond to what is currently in WINDOW 4 and WINDOW 5. The previous routine, based on an older WINDOW 4 .0 report, underestimated transmittance for angles of incidence >60 degrees. As shown in Figure 9 for the same SolRadGlazing case discussed in the previous section, excellent agreement was then obtained with the 1052-RP analytical results. The peak cooling load is now within 2%.

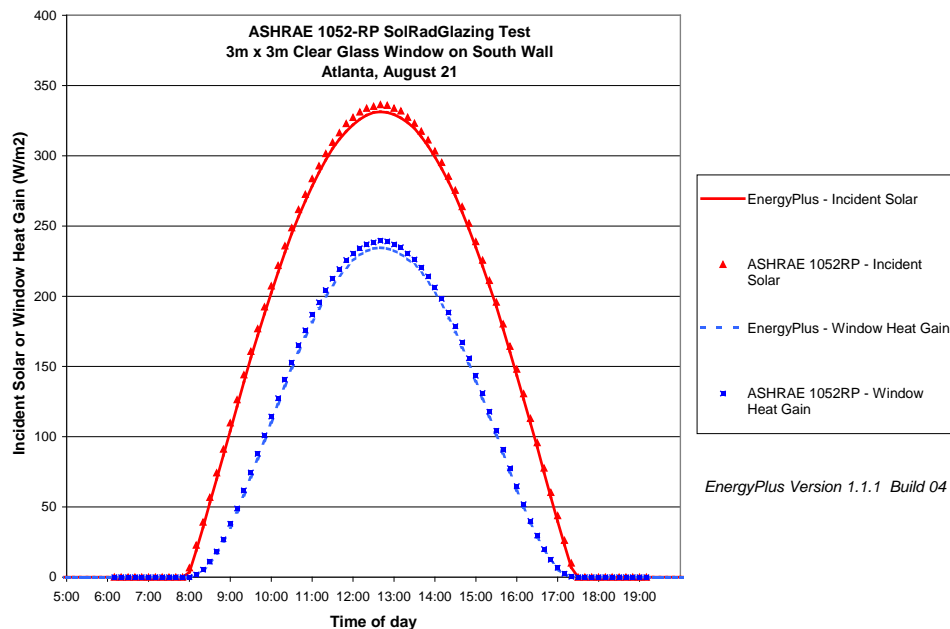

Figure 9 Results from ASHRAE 1052RP SolRadGlazing Analytical Test - Window Solar Gain, Atlanta, August 21, South Facing Clear Single-Pane Glass with Window Solar Transmittance Corrected

3.5 Summary of Pertinent Changes that Occurred Between Versions of EnergyPlus

This section summarizes the modifications that were made to the EnergyPlus code or changes that were made in the modeling approach during the testing of EnergyPlus with the ASHRAE 1052-RP toolkit. Since the testing of EnergyPlus with the ASHRAE 1052-RP toolkit first began with version 1.0 back in June 2001, further capabilities and improvements have been added to EnergyPlus with new releases in June 2002 (version 1.0.1), August 2002 (version 1.0.2), December 2002 (version 1.0.3), April 2003 (version 1.1.0), September 2003 (version 1.1.1), May 2004 (version 1.2.0), October 2004 (version 1.2.1), April 2005 (version 1.2.2), October 2005 (version 1.2.3), April 2006 (version 1.3.0), October 2006 (version 1.4.0.025), April 2007

(version 2.0.0.025), October 2007 (version 2.1.0.023), April 2008 (version 2.2.0.023), November 2008 (version 3.0.0.028) and April 2009 (version 3.1.0.027). The table below summarizes pertinent input file and code changes that were made as the testing progressed with each new public release of EnergyPlus.

Summary of Pertinent EnergyPlus Changes that were Implemented Over Course of 1052-RP Toolkit Testing

Version	Input File Changes	Code Changes
1.0.0.015		Fixed shade fin inverted coordinates problem
1.0.1.001		Change in weather processing file
1.0.1.008		Change in solar position calculation
1.0.1.010		Sunlit area calculation done for each timestep
1.0.1.037		Added ability to input monthly ground reflectance
1.1.1.004		Modify window calculation of transmittance and reflectance versus angle of incidence for single glass layer
1.0.1.040	Set monthly ground reflectance to 0.20. Previously defaulted to 0.2 – 0.6 depending on month	
1.0.1.026	Set SHADOW CALCULATIONS = 1; previously defaulted to 20	
1.0.3.006		Changed weather interpolation to previous hour
1.0.3.015		Changed to “half” interpolation for solar radiation
1.1.0.003	Set surface inside convection coefficients to constants for certain tests	New ConvectionCoefficients input object added
1.1.1.004		Changed surface convection coefficient algorithms
1.2.0		More changes to exterior convection coefficient algorithms
1.3.0.018	Included new SITE ATMOSPHERIC VARIATION object which allows calculation of local outdoor air temperature and wind speed for each exterior surface. Air temperature gradient coefficient set to 0.0 to lockout air temperature variation.	
1.3.018		Algorithm error corrected for calculating when sun comes up – sun rises 10 minutes earlier now
2.1.0.023		The methodology for handling solar diffuse through a window was completely reworked and was changed from uniform interior distribution of transmitted diffuse solar to distribution based on approximate view factors between transmitting windows and zone heat transfer surfaces. (CR7237)
3.0.0.028		The algorithm for variable system timestep was revised. Changes include uniform system timestep length across zone timestep and stricter management of history terms for zone air conditions.

Beginning with EnergyPlus version 1.3.0.018 a new SITE ATMOSPHERIC VARIATION input object became available (beginning with EnergyPlus 3.0.0 the name of this object changed to

Site:HeightVariation) to simulate changes in outside air temperature and wind speed that typically occur vertically across building surfaces versus the outdoor air temperature and wind speed that are obtained each hour from the weather file. Typically the meteorological wind speed is measured in an open field at 10m above the ground and meteorological air temperature is measured at 1.5m above ground level. To accommodate atmospheric variation EnergyPlus now automatically calculates the local outdoor air temperature and wind speed separately for each zone and surface exposed to the outdoor environment. The zone centroid or surface centroid are used to determine the height above ground. Only local outdoor air temperature and wind speed are currently calculated because they are important factors for the exterior convection calculation for surfaces and can also be factors in the zone infiltration and ventilation calculations. Since the ASHRAE 1052-RP analytical solutions assume that the temperature of the outside surfaces of the building are at the outdoor dry-bulb temperature read from the weather file, the SITE ATMOSPHERIC VARIATION temperature calculation feature was turned off by setting the air temperature gradient coefficient to 0.0. The wind effect variation was left turned on but had no effect on any of the tests because either the wind speed on the weather file was always 0.0 m/s or all exterior surfaces of the test zone were adiabatic (e.g. IntHeatGain test). The SITE ATMOSPHERIC VARIATION object inputs were set as shown below for all test cases.

SITE ATMOSPHERIC VARIATION,
0.22, !- Wind Speed Profile Exponent
370, !- Wind Speed Profile Boundary Layer Thickness {m}
0.0; !- Air Temperature Gradient Coefficient {K/m}

New output variables to report the surface exterior outdoor dry-bulb temperature and surface exterior wind speed allow the user to track hourly changes when the SITE ATMOSPHERIC VARIATION features are active.

The methodology for handling solar diffuse through a window was completely reworked in EnergyPlus 2.1.0.012 and was changed from uniform interior distribution of transmitted diffuse solar to distribution based on approximate view factors between transmitting windows and zone heat transfer surfaces. This change only affected the Test IntSolDist results. For all other tests the internal diffuse radiation was locked out.



4 CONCLUSIONS

EnergyPlus Version 4.0.0.024 was used to model a series of analytical tests for building envelopes as specified in ASHRAE 1052-RP report titled *Development of an Analytical Verification Test Suite for Whole Building Energy Simulation Programs – Building Fabric*. The ability of EnergyPlus to predict zone loads, surface heat fluxes and surface temperatures was tested using a test suite of 16 cases which tested various modes of heat transfer such as convection, conduction, radiation, solar gains and shading, infiltration, long wave radiation, and other miscellaneous tests. Comparison of results between EnergyPlus and the ASHRAE analytical solution for various test cases pointed to the following areas of significant difference:

Difference in window heat gains due to different approach to handling light polarization between EnergyPlus and the 1052 toolkit.

Differences for those tests where the 1052-RP hourly weather data had to be interpolated into subhourly data for 10 minute timesteps

Differences in treatment of external long wave radiation which may be due to differences in external long wave radiation models

Differences in treatment of ground-coupled heat transfer for slabs due to assumptions that had to be in order to use the EnergyPlus Slab program

Overall, the results of EnergyPlus compared very closely with the analytical results obtained from the ASHRAE 1052-RP Toolkit. The 1052-RP Toolkit proved to be very useful in detecting bugs and confirming that basic modeling algorithms were working properly.

5 REFERENCES

Building Systems Laboratory. 1999. *BLAST 3.0 Users Manual*. Urbana-Champaign: Building Systems Laboratory, Department of Mechanical and Industrial Engineering, University of Illinois.

EnergyPlus 2009. U.S. Department of Energy, Energy Efficiency and Renewable Energy, Office of Building Technologies. www.energyplus.gov

Spitler, J.D., Rees, S.J., and Dongyi, X., 2001. Development of an Analytical Verification Test Suite for Whole Building Energy Simulation Programs – Building Fabric, ASHRAE 1052-RP Final Report, April 2001.

Witte, M. J., Henninger, R.H., Glazer, J., and D. B. Crawley. 2001. "Testing and Validation of a New Building Energy Simulation Program," *Proceedings of Building Simulation 2001*, to be published in August 2001, Rio de Janeiro, Brazil, International Building Performance Simulation Association (IBPSA).

<http://www.energyplus.gov>